

PUNTATRICI DA BANCO
BENCH SPOT WELDING MACHINES
TISCH-PUNKTSCHWEISSMASCHINEN

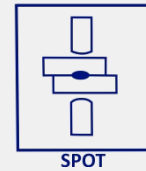

- Robusta struttura meccanica;
- Trasformatore, bracci, portaelettrodo ed elettrodo raffreddati ad acqua;
- Controllo sincrono a SCR;
- Termostati di sicurezza.
- Rugged steel frame;
- Water-cooled transformer, arms, electrode holders and electrodes;
- Synchronous welding control with SCR;
- Safety thermostats.
- Starke mechanische Struktur;
- Transformator, Arme, Elektrodenträger und Elektroden wassergekühlt;
- SCR-Synchronsteuerung
- Sicherheitsthermostate.

PFB series



PX1700

Controllo di saldatura digitale
Digital welding control
Digital Schweißsteuerung

CARATTERISTICHE TECNICHE	TECHNICAL DATA	TECHNISCHE DATEN		PFB 116	PFB 126	PFB 136
Potenza nominale al 50%	Nominal power @ 50% duty cycle	Nennleistung 50% ed	kVA	15	25	35
Corrente di corto circuito	Maximum short circuit current	Kürzschlussstrom	kA	14	17	19
Corrente secondaria di saldatura	Maximum welding current	Schweisstrom	kA	9,2	11	14
Forza agli elettrodi 6 bar	Electrodes force 6 bar	Elektrodenhub 6 bar	daN	185	185	185
Tensione di alimentazione (*)	Supply voltage (*)	Primarspannung (*)	V	400	400	400
Frequenza (*)	Frequency (*)	Nennfrequenz (*)	Hz	50	50	50
Fusibili ritardati	Delayed fuses	Sicherung	A	25	45	63
Scartamento e	Throat gap e	Armadstand e	mm	60-130	60-130	60-130
Profondità utile l	Throat depth l	Ausladung l	mm	275	275	275
Diametro bracci	Arms diameter	Durchemsser Arme	mm	35	35	35
Corsa elettrodi	Electrodes stroke	Elektroden Hub	mm	60	60	60
Peso	Weight	Gewicht	Kg	92	97	102

* Altre tensioni-frequenze a richiesta / Other voltages- Frequency on request / Sonderspannungen oder Nennfrequenz auf anfrage

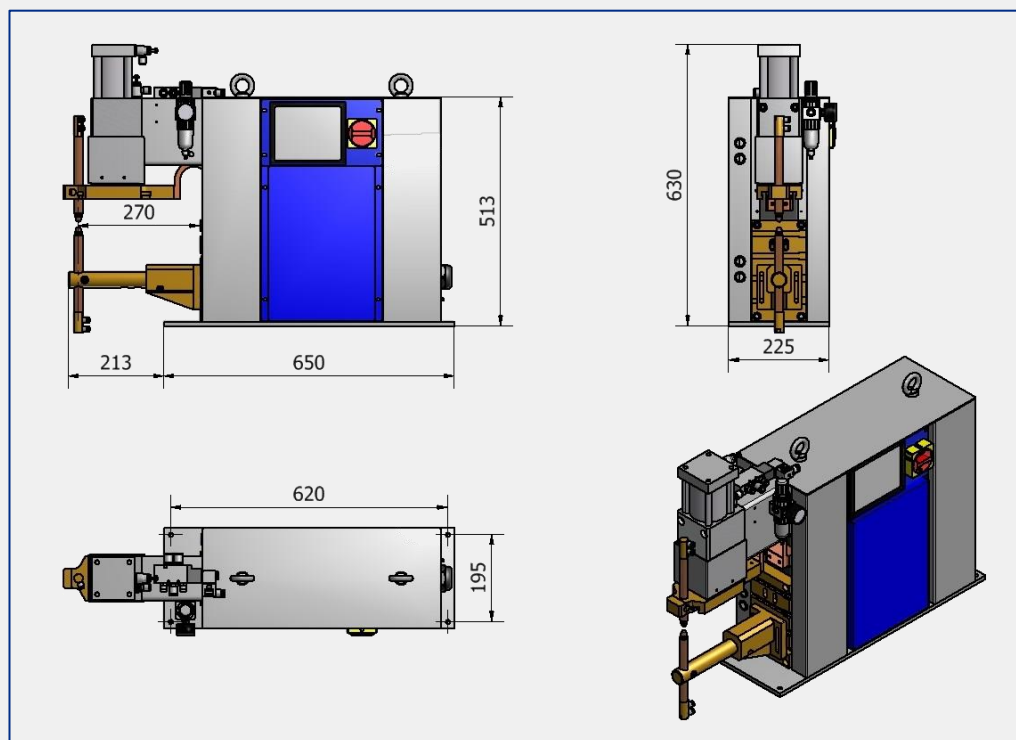

PFB comprensiva di Pedaliera cavo 2,5 mt
PFB includes Electric Pedal cable 2,5m
PFB inklusive Elektrische Pedal mit Kabel 2,5m

P.E.I.-POINT si riserva il diritto di modificare le specifiche senza alcun preavviso
P.E.I.-POINT reserve the right to modify specifications without prior notice
P.E.I.-POINT behält sich das Recht die spezifischen ohne Benachrichtigung zu ändern vor