

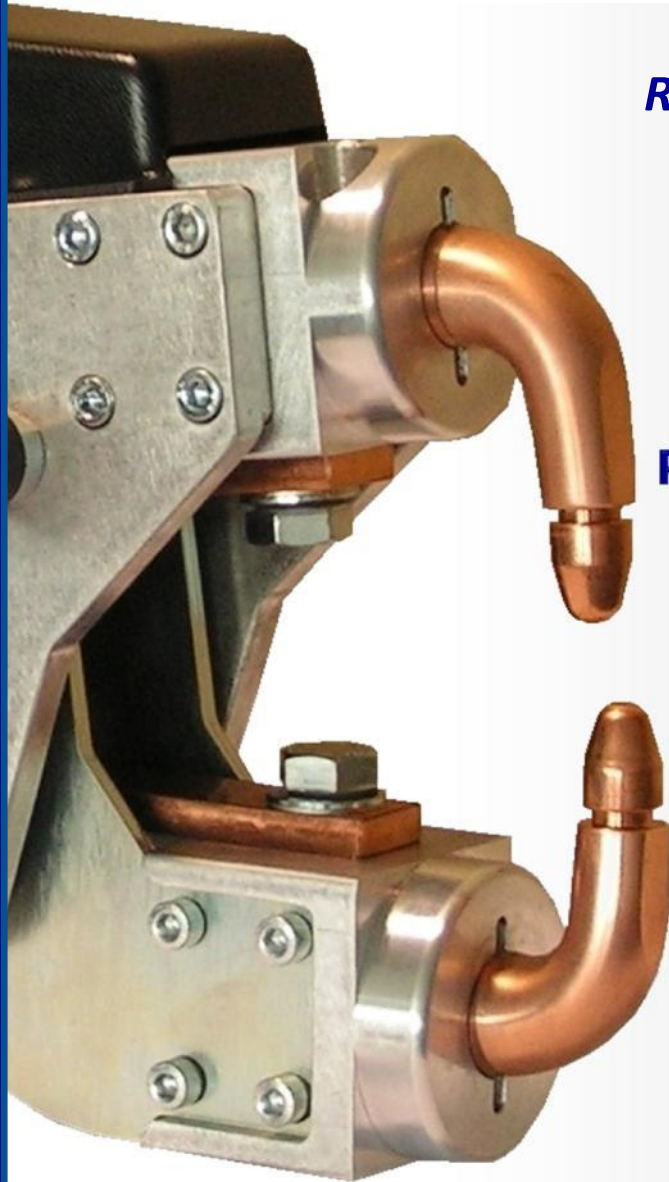

WELD-TEC

SCHWEISS- UND SCHNEIDTECHNIK GMBH

Resistance Welding Solutions



**PUNKTSCHWEISSGERÄTE
FÜR AUTOKAROSSERIE**

**MOVABLE WELDERS
FOR AUTO BODY REPAIR**





HANDPUNKTSCHWEISSZANGE 2,5kVA
HAND HELD DUTY LIGHT GUN 2,5kVA



STOSSPUNKTER 3,5 ECO
FAST SPOTTER 3,5 ECO



CAR POINT 8 MULTIFUNKTIONS-PUNKTSCHWEISSGERÄT 8kVA
CAR POINT 8 MOVABLE WELDER 8kVA
CAR POINT 11 MULTIFUNKTIONS-PUNKTSCHWEISSGERÄT WGK 11kVA
CAR POINT 11 WATER-COOLED MOVABLE WELDER 11kVA



X-ZANGE 125daN LUFTGEKÜHLT
 NOT WATER-COOLED X GUN 125daN



X-ZANGE 125daN WASSERGEKÜHLT
 WATER-COOLED X GUN 125daN



EUROPEI 18 MULTIFUNKTIONS-PUNKTSCHWEISSGERÄT WGK 18kVA
EUROPEI 18 WATER-COOLED MOVABLE WELDER 18kVA



X-ZANGE 245daN WASSERGEKÜHLT
 WATER-COOLED X GUN 245daN

AS25-13K INVERTER



X-ZANGE 245daN WASSERGEKÜHLT
WATER-COOLED X GUN 245daN



X-ZANGE 370daN - 560daN WASSERGEKÜHLT
WATER-COOLED X GUN 370daN - 560daN



C-ZANGE 430daN - 600daN WASSERGEKÜHLT
WATER-COOLED C GUN 430daN - 600daN



AS25-13K MULTIFUNKTIONS-PUNKTSCHWEISSGERÄT
INVERTER

AS25-13K MULTIFUNCTION INVERTER SPOT WELDER



PY700 SCHWEISSSTEUERUNG
PY700 WELDING CONTROL



SPEICHERUNG DER SCHWEISSDATEN AUF USB-STICK
STORAGE OF WELDING DATA ON USB PEN DRIVE

WELD-TEC

SCHWEISS- UND SCHNEIDTECHNIK GMBH



AS25-15K INVERTER



AS25-15K MULTIFUNKTIONS SCHWEISSEINHEIT IN INVERTERTECHNOLOGIE MIT MITTELFREQUENZ-SCHWEISS-TRANSFORMATOR AN DER ZANGE

AS25-15K MULTIFUNCTION WELDING UNIT WITH INVERTER TECHNOLOGY. MEDIUM FREQUENCY WELDING TRANSFORMER FITTED ON THE GUN



MITTELFREQUENZ X-ZANGE 370daN - 560daN
MEDIUM FREQUENCY X GUN 370daN - 560daN



MITTELFREQUENZ C-ZANGE 430daN - 600daN
MEDIUM FREQUENCY C GUN 430daN - 600daN



PY700 SCHWEISSSTEUERUNG
PY700 WELDING CONTROL

NEUES INVERTER SYSTEM MIT AUTOMATISCHER MATERIAL- UND MATERIALSTÄRKE ERKENNUNG

NEW INVERTER SYSTEM RECOGNIZING THICKNESS AND MATERIAL WITH AUTOMATIC SETUP



SPEICHERUNG DER SCHWEISSDATEN AUF USB-STICK
STORAGE OF WELDING DATA ON USB PEN DRIVE

LUFTGEKÜHLTE ARME FÜR X-ZANGE 125daN CAR POINT 8
NOT COOLED ARMS X GUN 125daN CAR POINT 8

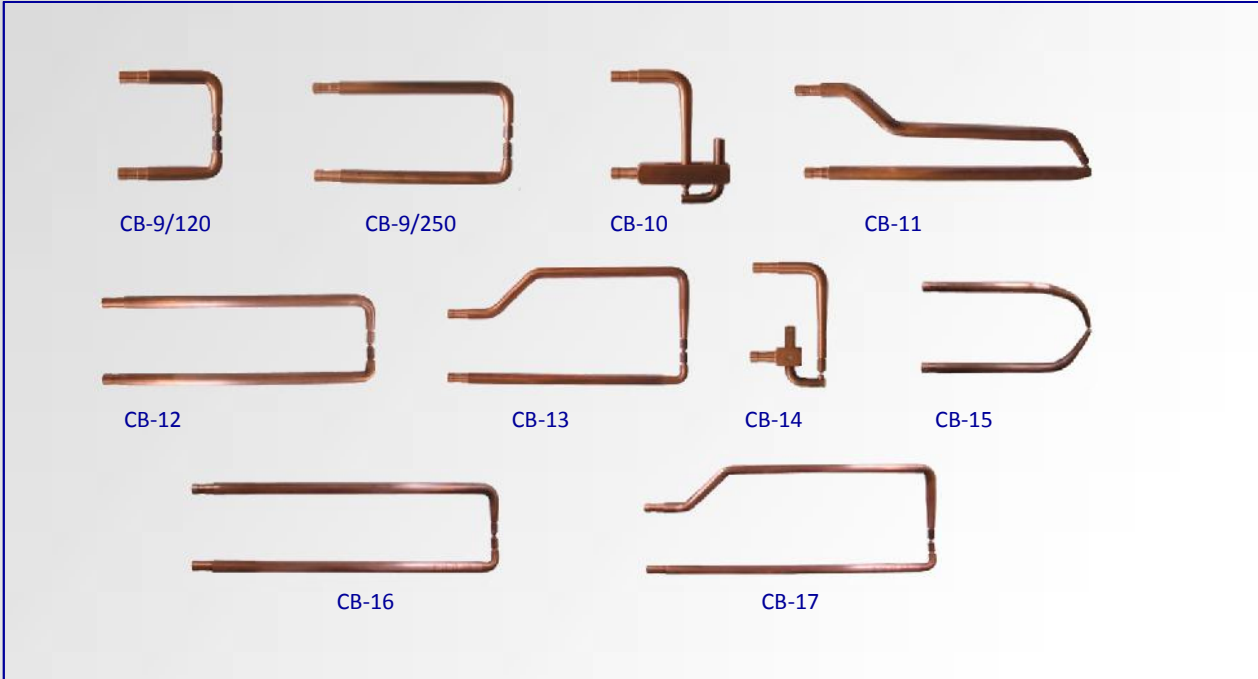

WASSERGEKÜHLTE ARME FÜR X-ZANGE 245daN CAR POINT 11 – EUROPEI 18 – AS25-13K 245 X
WATER-COOLED ARMS X GUN 245daN CAR POINT 11 – EUROPEI 18 – AS25-13K 245 X

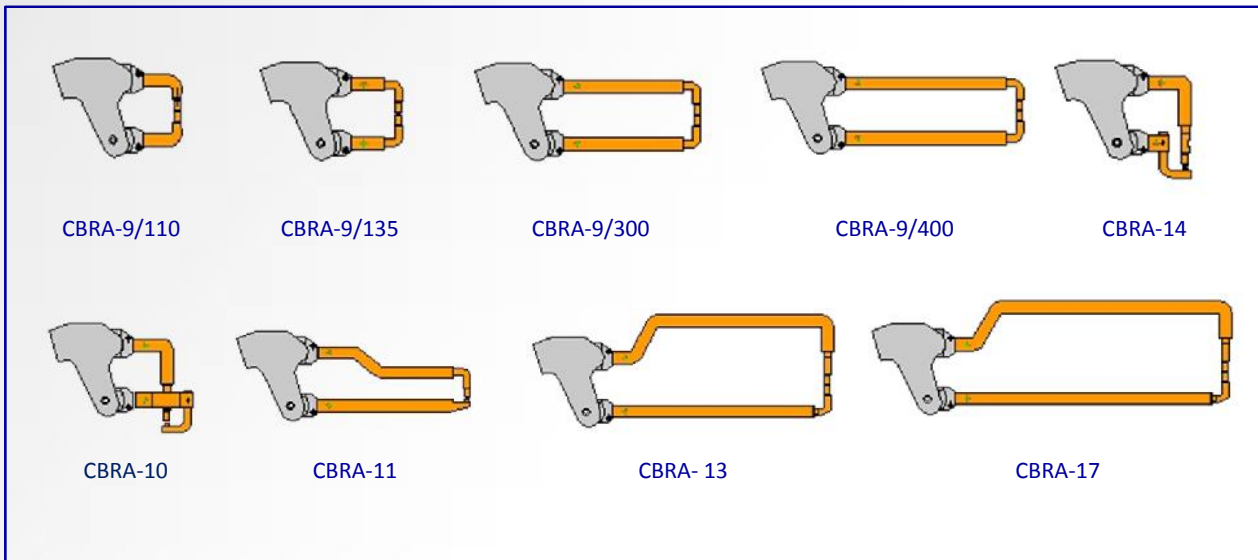

WASSERGEKÜHLTE ARME FÜR X-ZANGE 370daN 560daN AS25-13K / AS25-15K
WATER-COOLED ARMS X GUN 370daN 560daN AS25-13K / AS25-15K

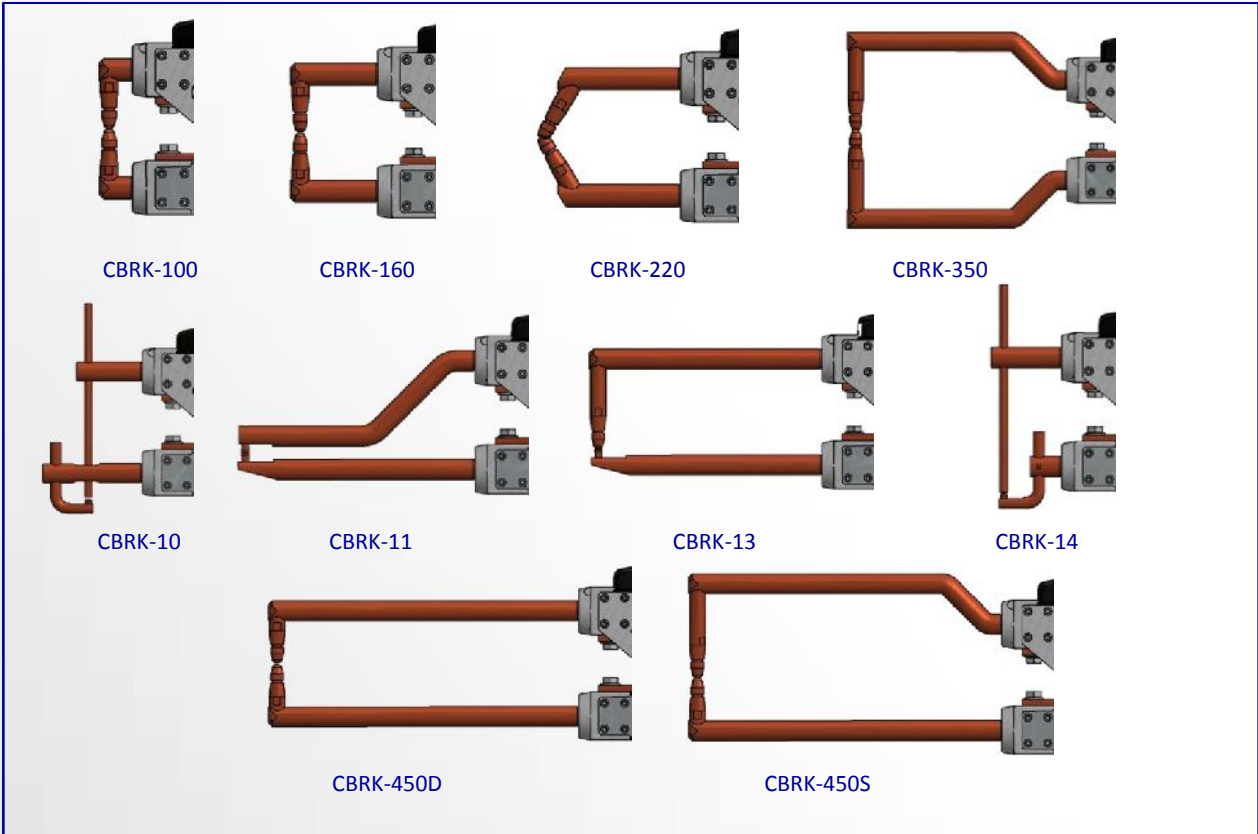

WASSERGEKÜHLTE ARME FÜR C-ZANGE 430daN - 600daN AS25-13K / AS25-15K
WATER-COOLED ARMS C GUN 430daN - 600daN AS25-13K / AS25-15K



TECHNICAL DATA – TECHNISCHE DATEN

		FAST SPOTTER 3,5 ECO	CAR POINT 8	CAR POINT 11 RF	EUROPEI 18	AS25-13K	AS25-15K
Nominal Power @ 50% duty cycle Nennleistung bei 50% ED	kVA	2,8	8	11	18	25	13
Max short circuit secondary current Max. sekundärer Kurzschlußstrom	kA	3	7	7	8,5	13	15
Supply voltage Netzanschluss	V	400V - 2ph	400V - 2ph	400V - 2ph	400V - 2ph	400V - 3ph	400V - 3ph
Sekundärspannung Secondary no load voltage	V	6,6	6,6	6,6	9,5	16	6,5
Delayed fuses Träge Sicherungen	A	16	20	20	32	32	16/32
Electrodes force @ 8 bar Kontaktdruck bei 8 bar	daN	-	125	125	245	1* = 370 2* = 560 3* = 430 4* = 600	1* = 370 2* = 560 3* = 430 4* = 600
Welding cables length Schweißkabellänge	m	-	1,9	1,9	2	2,5	3
Cooling gun cables Kühlung Kabel Zange		-	-	water Wasser	water Wasser	water Wasser	water Wasser
Spotter cables length Spotterkabellänge	m	1,8+1,8	1,5+1,8	1,5+1,8	1,5+1,8	2,5+2,5	2,5+2,5
Cooling spotter cables Kühlung Spotter Kabeln		-	-	-	-	air Luft	air Luft
X gun inlet arms diameter X Zange Arme Durchmesser	mm	-	16	20	20	24	24

1* = X-ZANGE 370daN

2* = X-ZANGE 560daN

3* = C-ZANGE 430daN

4* = C-ZANGE 600daN

P.E.I.-POINT behält sich das Recht vor, Spezifikationen ohne Vorankündigung zu ändern

P.E.I.-POINT reserve the right to modify specifications without prior notice