

POSITIONING RANGE

Since control over the welding process is the key to any system's performance, Lincoln Electric offers a full range of positioning equipment.

This high quality and robust equipment can be combined with any processes.

The good choice in this complete positioning range, depends on the characteristics of the piece to manipulate.



The **Mechanization** to customize the machine around the piece to weld.



The **Headstocks** 2 or 3 axis to manipulate medium piece in all positions.



The **Rotators** to position large vessels for welding.

The **Positioners** to allow the positioning of the piece in 2 or 3 axis.





2017-401

The **Seamer benches** for longitudinal weld of plates or vessels.



2009-360

The **Gantry machines** to weld large pieces in longitudinal with 2 heads.

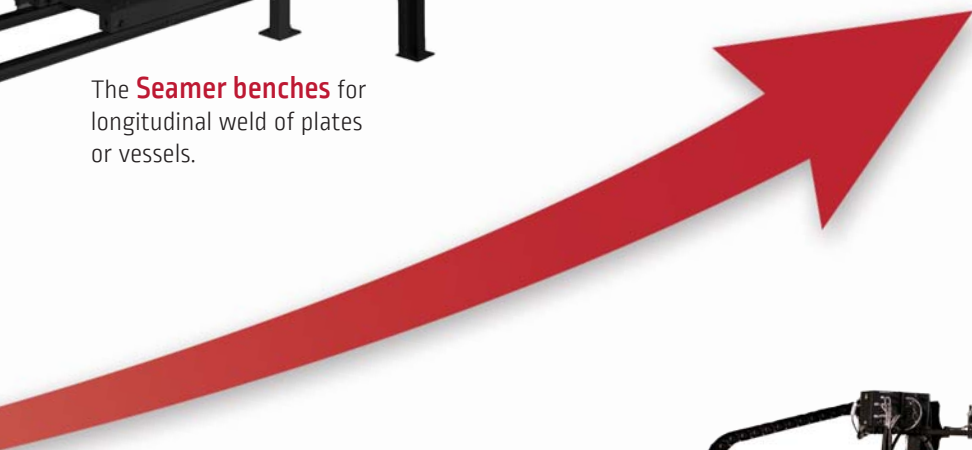

2013-148

The **Turntables** to turn the piece for positioning or for welding.

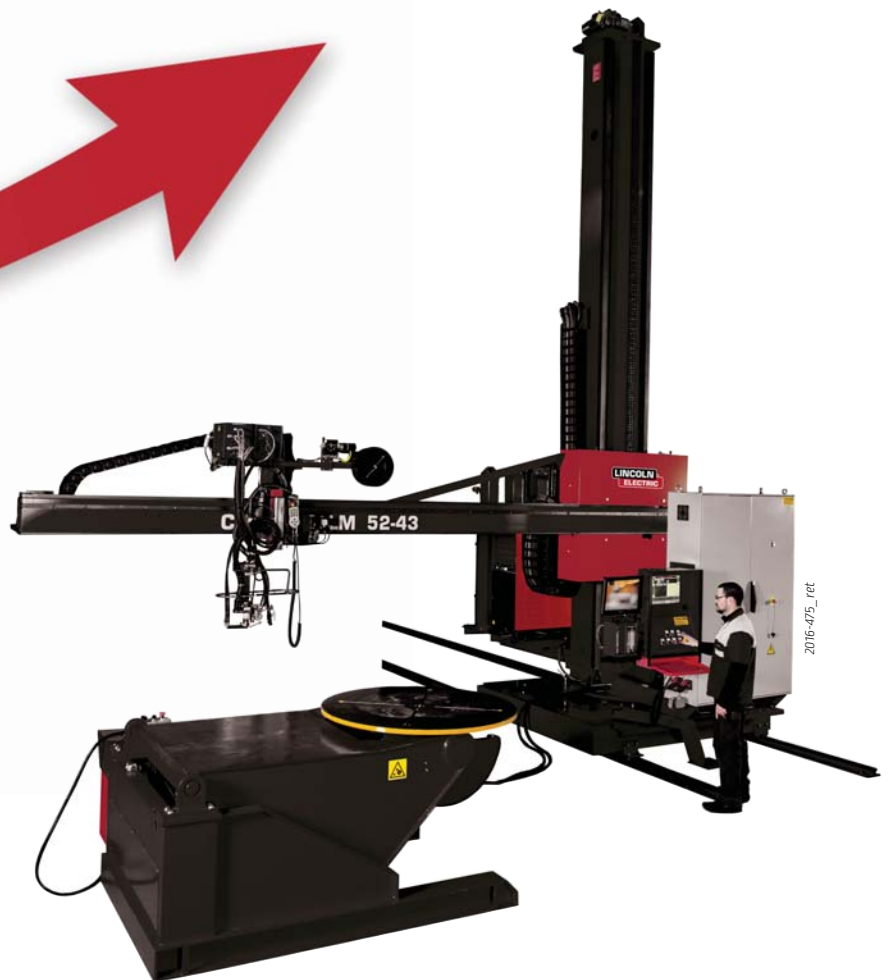

2016-475_ret

The **Column & Booms** to weld large tanks with any processes.

CB-MATIC: column and booms

Lincoln Electric column and booms are the professional answer to your needs.

Ideal for pressure vessels manufacturer of stainless steel, mild steel and light alloy, they maximise your benefit from automatic MIG/MAG, submerged arc, TIG, plasma and plasma + TIG welding processes.

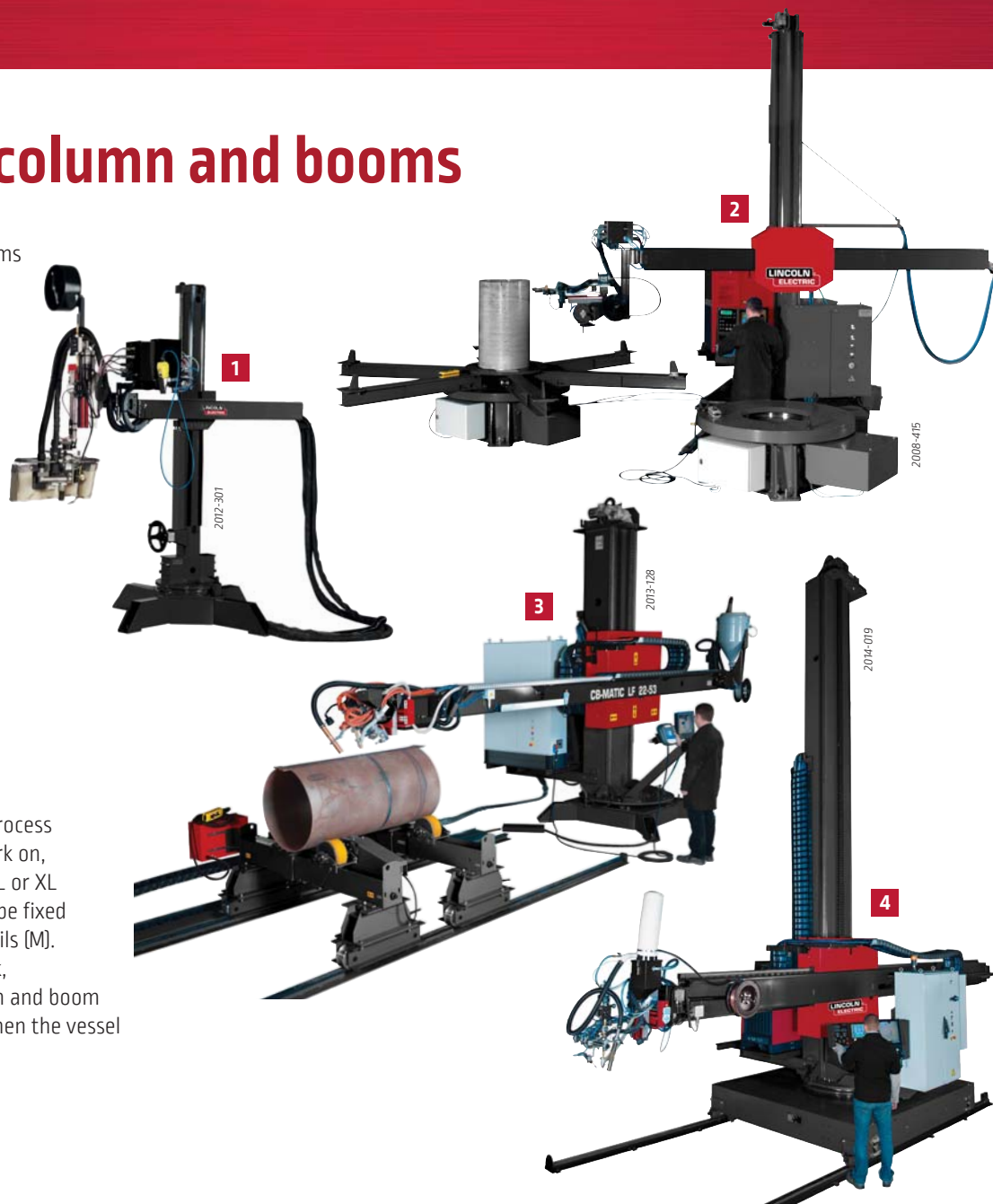

Column and boom choice

According to the welding /cutting process and the size of the vessels to work on, it is possible to choose for XS, S, L or XL column and boom. This C&B can be fixed on the ground (F) or mobile on rails (M). For the heavy and intensive work, we preonize to use the L column and boom and for large tank the XL type when the vessel size required it.

		15 x 10	25 x 23	32 x 33	42 x 43	52 x 43	62 x 43	52 x 53	62 x 63	72 x 73	Speed			
Vertical stroke (mm)		1 500	2 500	3 200	4 200	5 200	6 200	5 200	6 200	7 200	Arm speed	Carriage speed	Lifting speed	
Horizontal stroke (mm)		1 000	2 300	3 300	4 300	4 300	4 300	5 300	6 300	7 300	cm/min	cm/min	cm/min	
A Maxi load at the end of the arms (kg) + B Height (mm) without rail	1 XSF	A	200	80							Manual or 12 to 300		Manual or 120	
		B	2 625	3 625										
	XSM	A	200	80								Manual or 12 to 300	Manual or 57 to 570	Manual or 120
		B	2 630	3 630										
	2 SF	A		200	175	150						20 to 300 or 5 to 300		110 or 5 to 110
		B		4 580	5 280	6 280								
	SM	A		200	175	150						20 to 300 or 5 to 300	20 to 500 or 5 to 500	110 or 5 to 110
		B		4 635	5 335	6 335								
	3 LF	A		400	400	300	300	300	150			20 to 500 or 5 to 500		110 or 5 to 160
		B		4 850	5 550	6 550	7 550	8 550	7 550					
	LM	A		400	400	300	300	300	150			20 to 500 or 5 to 500	20 to 500 or 5 to 500	110 or 5 to 160
		B		4 850	5 550	6 550	7 550	8 550	7 550					
XLF	A				400	400	400	400	400	300	5 to 500		160 or 5 to 160	
	B				7 075	8 075	9 075	8 075	9 075	10 075				
4 XLM	A				400	400	400	400	400	300	5 to 500	20 to 500	160 or 5 to 160	
	B				7 125	8 125	9 125	8 125	9 125	10 125				

Standard equipment

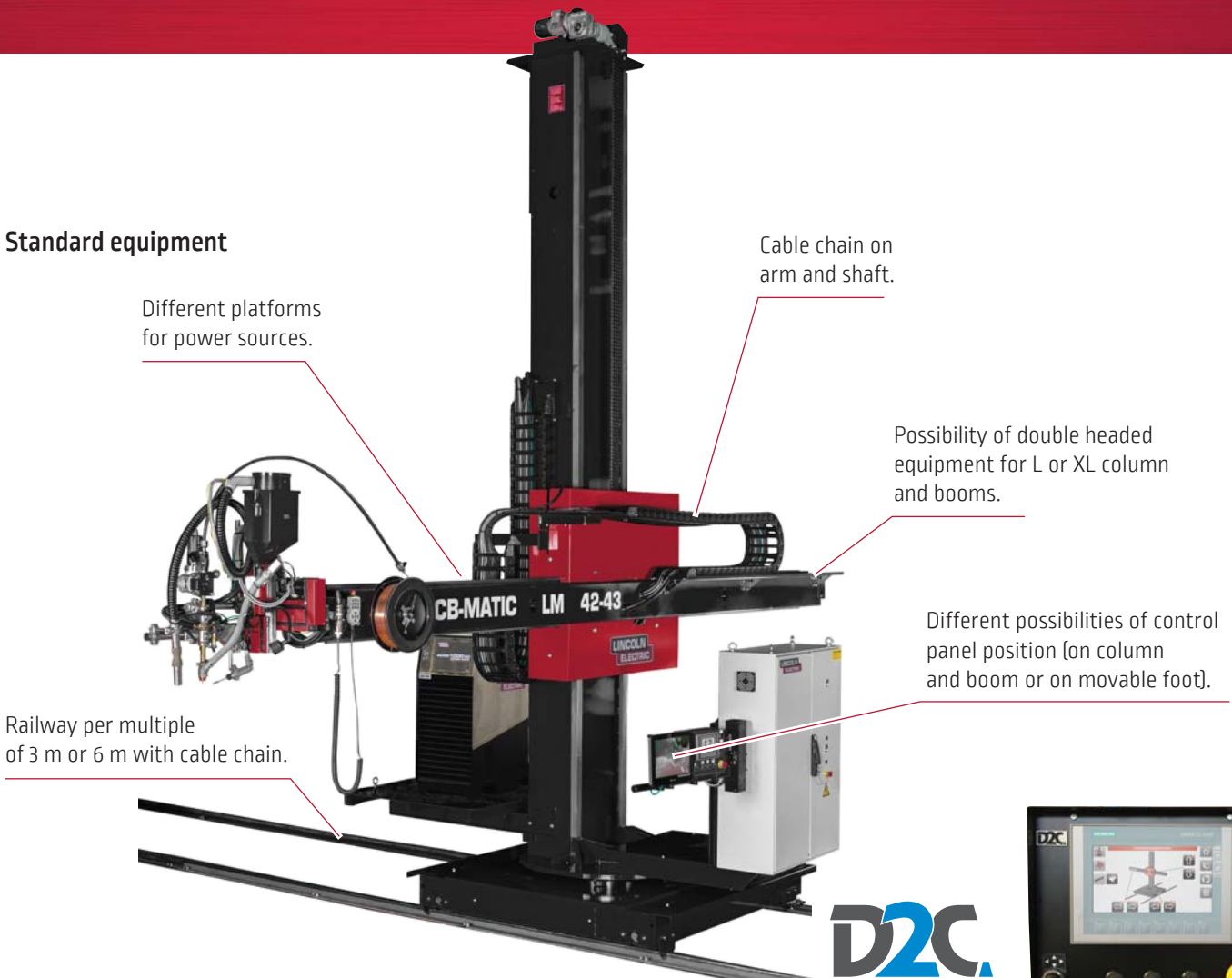

Control command

Column and boom specific size.

According to the process, the column and boom can be equipped with D2C or HPW control.



D2C control panel



HPW Advanced control panel

Customized solutions

Column and boom big size and specific size.

Peripherals integration, seamer, positioning equipment.

Special configuration to adapt to customer environment.

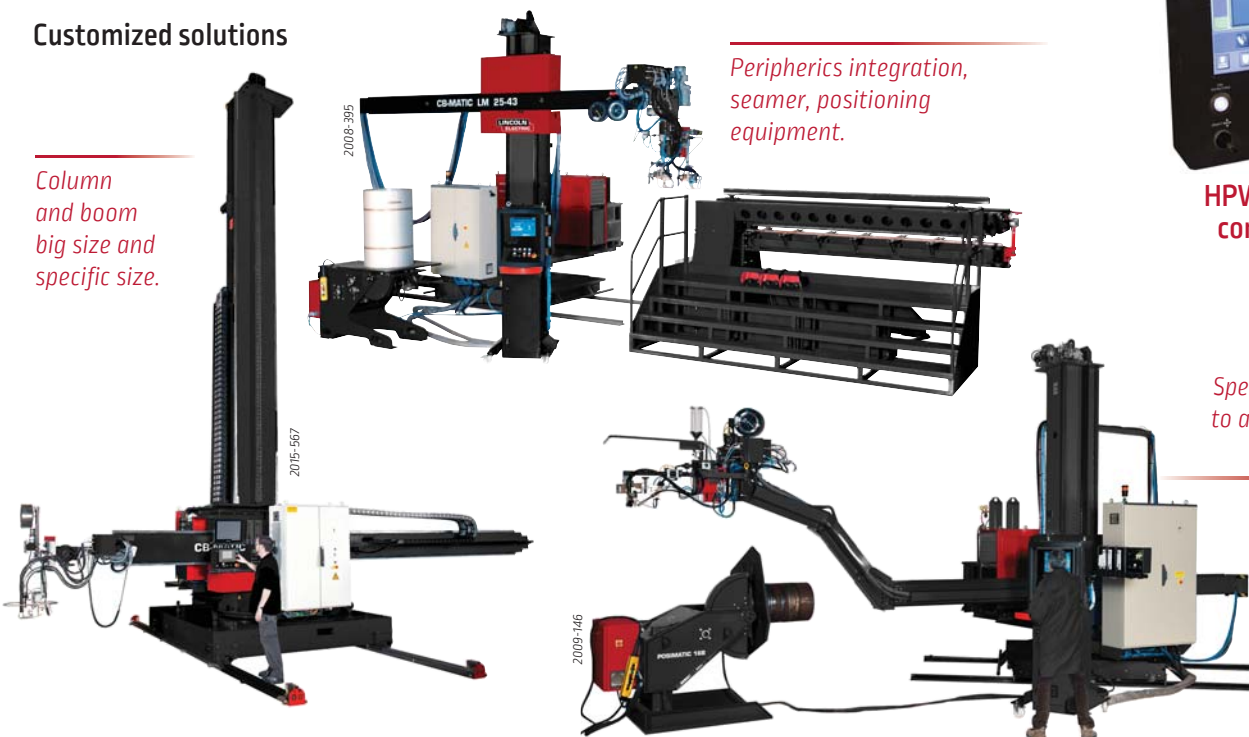

SEAM-MATIC: welding seamer benches

Lincoln Electric offers a range of seamers specifically designed for horizontal welding, supporting flat or cylindrical (round or square section) workpieces with a wide range of dimensions.

4 types of seamers: FIN: small thickness, EX: external welding, IT: internal welding and EXIT: external/internal welding.

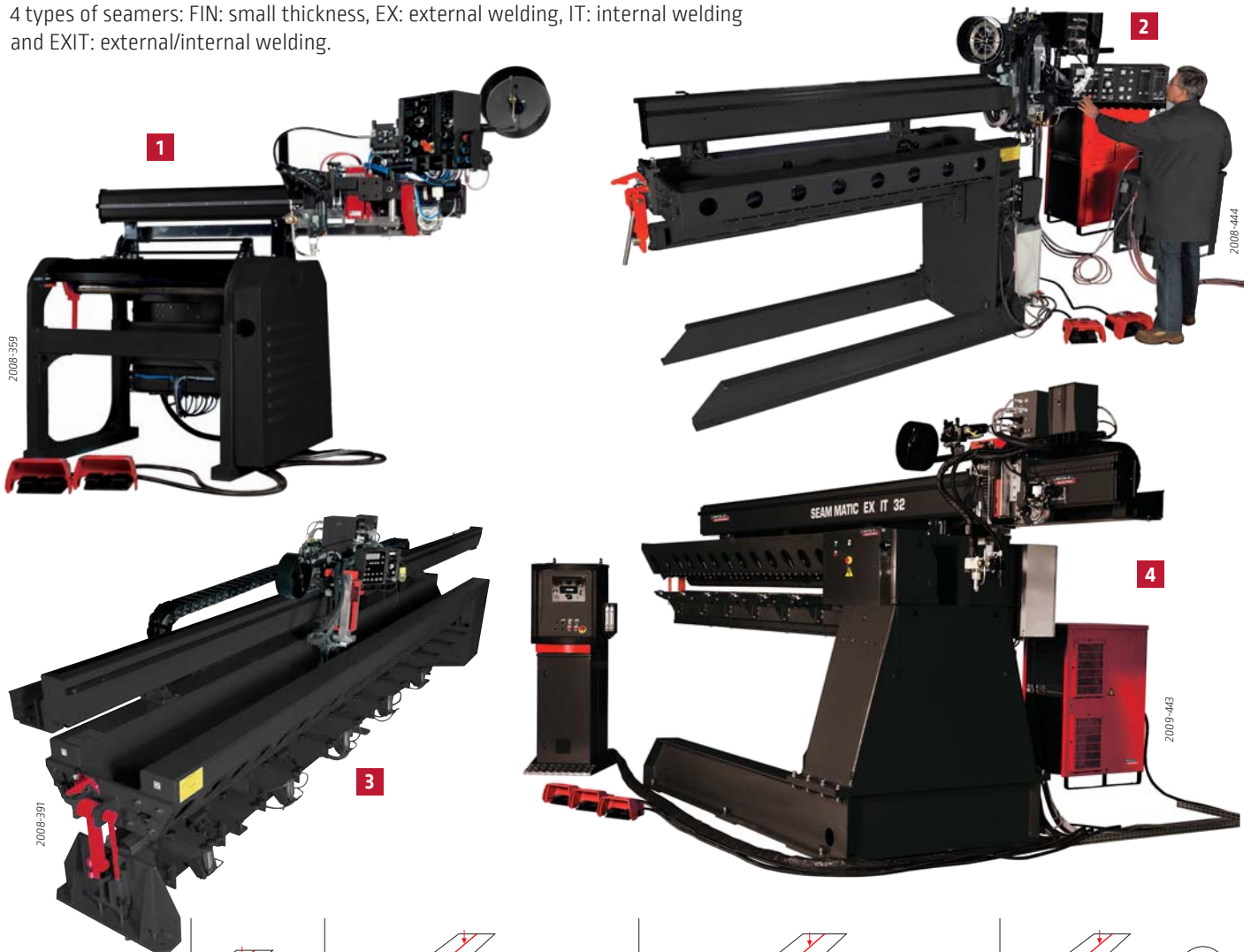

		1		2					3					4			
		FIN		EX (xx from 10 to 20)					IT					EXIT			
		10V07	12Vxx	17Vxx	22Vxx	32Vxx	42Vxx	22	32	42	52	62	72	32	42	52	62
Clamping Length *		1 050	1 250	1 750	2 250	3 250	4 250	2 250	3 250	4 250	5 250	6 250	7 250	3 250	4 250	5 250	6 250
External welding (mm)	∅ mini	80	210	220	270	320	460	-	-	-	-	-	-	380	480	580	600
	∅ maxi	700	xx00	xx00	xx00	xx00	xx00	-	-	-	-	-	-	1 500	1 500	1 550	1 600
Internal welding	∅ mini	-	-	-	-	-	-	1 450	1 500	1 500	1 550	1 600	1 650	1 500	1 500	1 550	1 600
Thickness (mm)	without tacking	0.6 to 3	0.8 to 5	0.8 to 5	1 to 5	1 to 5	1 to 5	1 to 5	1 to 5	1 to 5	1 to 5	1 to 5	1 to 5	1 to 5	1 to 5	1 to 5	1 to 5
	with tacking	0.6 to 3	0.8 to 8	0.8 to 8	1 to 8	1 to 8	1 to 8	1 to 10	1 to 10	1 to 10	1 to 10	1 to 10	1 to 10	1 to 10	1 to 10	1 to 10	1 to 10

* Maxi weldable length depends of head's configuration (number of torches and their options). To be confirmed on request.

Other dimensions or types on request.

Standard equipment

Cable chain

In standard configuration on all models

Control panel

For all seamers, possibility to have control panel on the welding head or on movable foot.

Open device

In standard, the open device is manual. For the EX seamer, there is the possibility to have a pneumatic or electric open device.



Digital controller D2C

Control pedal

Operating pedals used to open or close the clamps.

Control command

Simple analogical command through the process command panel or numerical command through the PLC command with HMI - D2C.

Customised solutions

According to the customer's needs, we could adapt the sizes and the process to reach the best productivity and quality.

Operator platform.



Large seamer with infeed and outfeed table.



Seamer with lifting for variable diameter vessels.



Mechanisation

Lincoln Electric proposes to design machines with modular elements in order to build the machine around the piece to be welded.

The mechanisation allows to save time for your project of machine.

Machine design

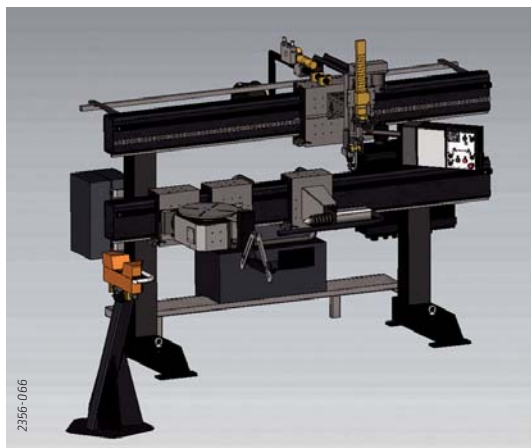

Machine realisation

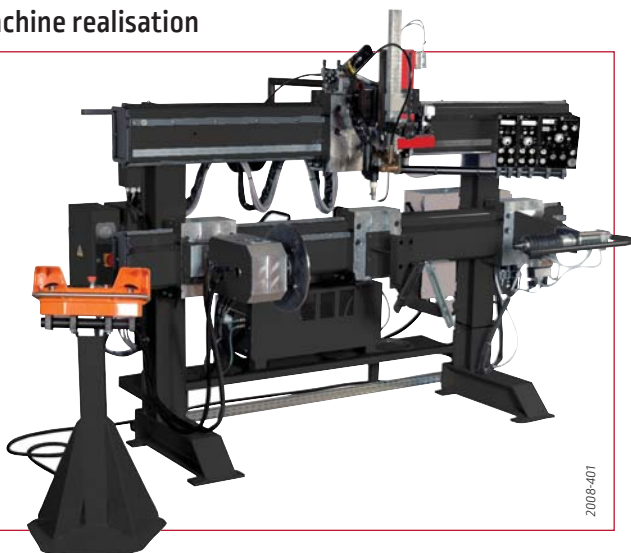

A large choice of mechanisation parts



Beam, carriage, manual or motorised slides...

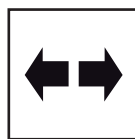

Oscillation mechanism...



Headstock, tailstock, rotation block, mandrel...

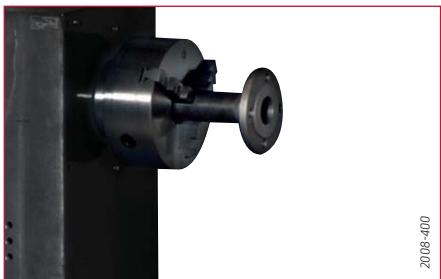

X rotators, support blocks, command box supports...



Trackmatic probes, mechanical tracking...

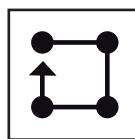
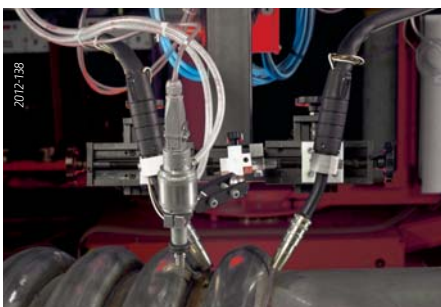

Cycle control boxes, electrical cabinet...



Examples of mechanisation machines

Double MIG/MAG mechanisation
for endless screw welding



MIG/MAG gantry for aluminium train welding

SAW platform
for school training

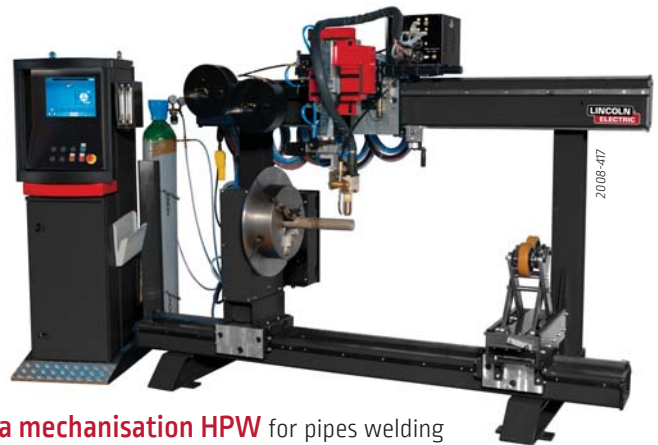

Plasma mechanisation HPW for pipes welding

Headstock mechanisation
for process piping

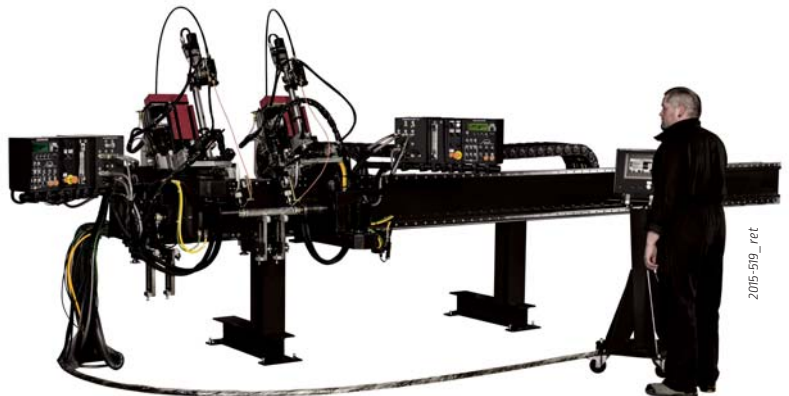

Lathe 2 torches for TIG welding
of aluminium tubes

ROTAMATIC: single roller beds

Medium-duty rotator: 2 to 30 tons

- Single powered (one drive roller) for small unbalance work piece.
- Double powered (two drive rollers) for work pieces having significant unbalance.
- Roller-to-roller center distance adjusting by screw (except for ST 2: by step).
- Remote pendant, kit auto and digital display on all versions.



Possible options:

- Kit $\pm 1\%$ speed regulation,
- Kit encoder 5 000 pts,
- Lorry and railway.

Technical specifications:

Designation		Load capacity (1 drive + 1 idler) kg	Load capacity per section kg	Shell diameter mm	Peripheral speed cm/min	Wheel dimension OD x width mm	Wheel material
ST 2	MT	2 000	1 000	30 to 2 500	12 to 120	\varnothing 150 x 50	Polyurethane
	M						Polyamide
	W						
	F						
ST 6	M	6 000	3 000	300 to 3 500	12 to 120	\varnothing 250 x 75	Polyurethane
	W						
	F						
ST 15	M	15 000	7 500	300 to 4 000	12 to 120	\varnothing 250 x 110	Polyurethane
	W						
	F						
ST 30	W	30 000	15 000	350 to 4 500	12 to 120	\varnothing 350 x 150	Polyurethane
	F						

Keys: M = Single motorisation / W = Double motorisation / F = Idler roller / MT = Single motorisation with tube system

Special roller beds

Small 6 tons roller beds \varnothing 100 to 600 mm



Special roller beds with large diameter rollers.

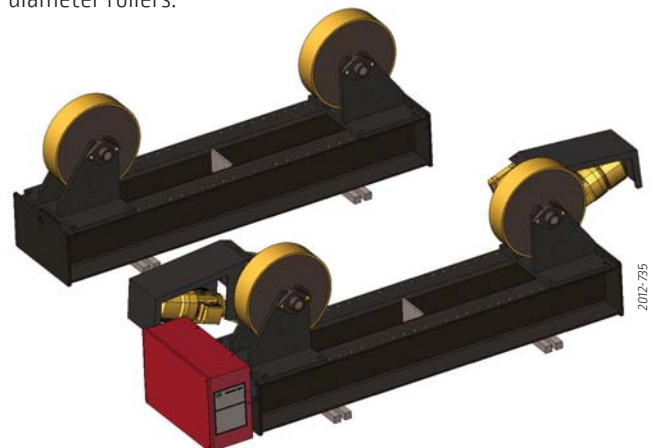

Heavy-duty roller beds: 30 to 500 tons

- Each rotator is composed of a mechanical structure and rotation roller motorized with roller adjustment by step or screw. In the motorized version, the rotator is equipped with an electrical cabinet.
- Remote pendant, with 30 m cable and kit auto in standard on all versions.

Possible options:

- Lorry and railway,
- End stop, encoder,
- Digital display.

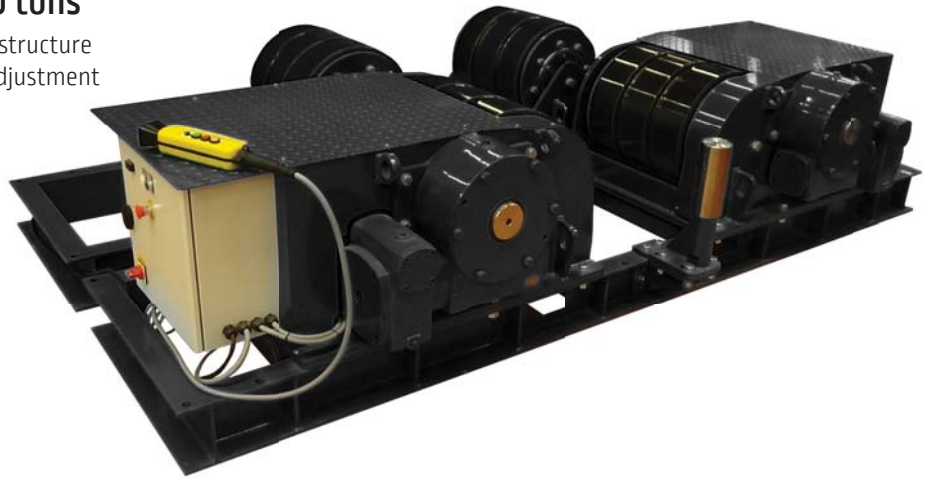

Technical specifications:

Designation	Load capacity (1 drive + 1 idler) kg	Load capacity per section kg	Shell diameter mm	Peripheral speed cm/min	Wheel dimension OD x width mm	Wheel material
CR 30*	30 000	15 000	570 to 6 800	14 to 140 or 10 to 185	Ø 520 x 150	Steel
					Ø 520 x 178	Polyurethane
CR 60*	60 000	30 000	570 to 6 800	14 to 140 or 10 to 185	Ø 520 x 150	Steel
					Ø 520 x 355	Polyurethane
CR 100*	100 000	50 000	570 to 6 800	14 to 140 or 10 to 185	Ø 520 x 150	Steel
					Ø 520 x 533	Polyurethane
CR 125*	125 000	62 500	570 to 6 800	14 to 140 or 10 to 185	Ø 520 x 150	Steel
					Ø 520 x 710	Polyurethane
CR 200*	200 000	100 000	570 to 6 800	10 to 100 or 9 to 160	Ø 600 x 175	Steel
					Ø 558 x 685	Polyurethane
CR 300*	300 000	150 000	800 to 7 500	10 to 100 or 9 to 160	Ø 700 x 230	Steel
					Ø 860 x 406	Polyurethane
CR 500*	500 000	250 000	1250 to 7 500	10 to 100 or 9 to 160	Ø 700 x 230	Steel
					Ø 860 x 686	Polyurethane

* Available in version D (Drive double motorisation) or I (Idler roller)

Higher capacity roller beds on request.



ROTAMATIC: fit-up roller beds

Fit-up roller beds: 30 to 500 tons

- In standard, the up and down movement is made by a manual hydraulic pump.
- Spacing rotation roller with adjustment by step.

Possible options:

- Automatic hydraulic pump (hydraulic central),
- Lorry and railway.



2356-063_net

Technical specifications:

Designation	Load capacity (2 fit-up) kg	Lifting capacity per section kg	Shell diameter mm	Wheel dimension OD x width mm	Wheel material	Wheels adjustment
FR 30	30 000	15 000	570 to 6 800	Ø 520 x 178	Polyurethane	Step
FR 60	60 000	30 000	570 to 6 800	Ø 520 x 355	Polyurethane	Step
FR 100	100 000	50 000	570 to 6 800	Ø 520 x 533	Polyurethane	Step
FR 200	200 000	100 000	570 to 6 800	Ø 558 x 685	Polyurethane	Step
				Ø 600 x 175	Steel	Step
FR 300	300 000	150 000	800 to 7 500	Ø 860 x 406	Polyurethane	Step
				Ø 700 x 230	Steel	Step
FR 500	500 000	250 000	1 250 to 7 500	Ø 700 x 230	Steel	Step

Higher capacity roller beds on request.

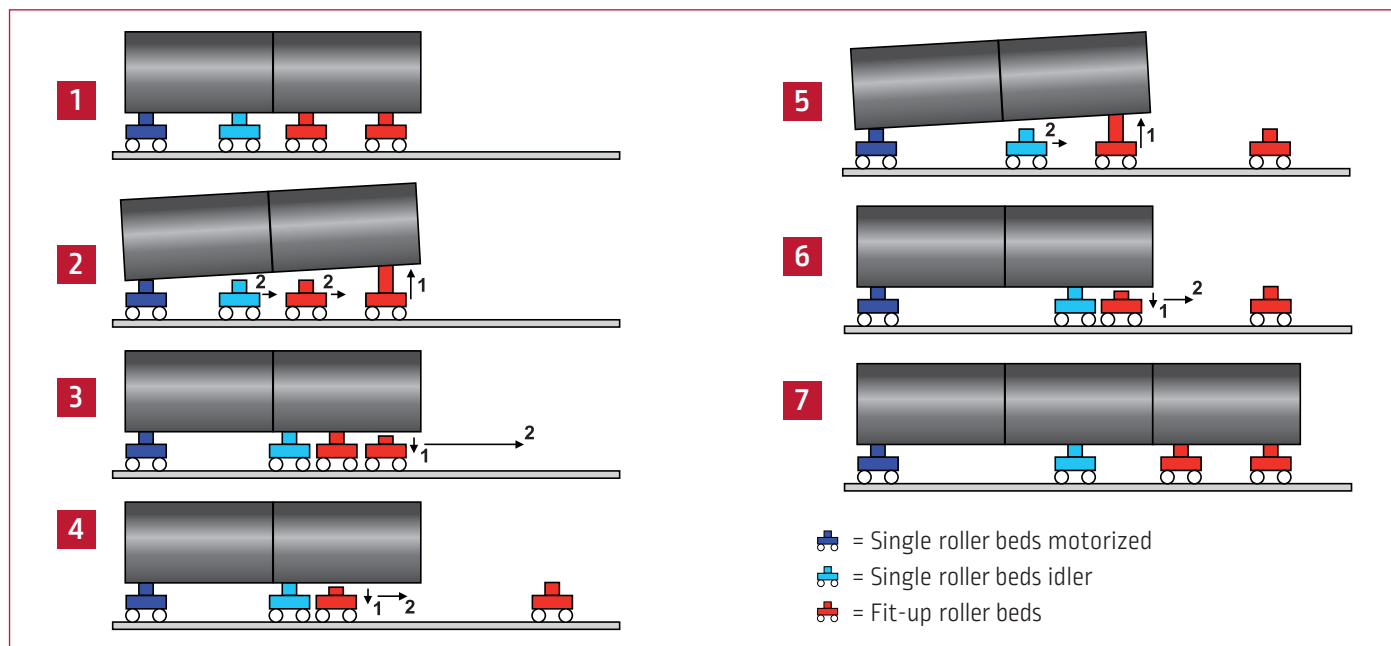

Version with automatic hydraulic central:



ROTAMATIC: self aligning roller beds

5 to 500 tons

- Each roller bed is composed of a mechanical structure and rotation roller motorized or not.
- In the motorized version, the rotator is equipped with an electrical cabinet.
- In standard: remote pendant with 30m cable, and kit auto on all versions.

Possible options:

- Lorry and railway,
- End stop, encoder,
- Digital display.



Technical specifications:

Designation	Load capacity [1 drive + 1 idler] kg	Load capacity per section kg	Shell diameter mm	Peripheral speed cm/min	Wheel dimension OD x width mm	Wheel material
ACR 5*	5 000	2 500	380 to 3 000	14 to 140 or 10 to 200	Ø 254 x 102	Rubber
ACR 10*	10 000	5 000	450 to 4 600	14 to 140 or 10 to 200	Ø 381 x 127	Rubber
ACR 20*	20 000	10 000	450 to 4 600	14 to 140 or 10 to 200	Ø 381 x 127	Polyurethane
ACR 30*	30 000	15 000	450 to 5 200	14 to 140 or 10 to 200	Ø 457 x 127	Polyurethane
ACR 60*	60 000	30 000	450 to 5 200	14 to 140 or 10 to 200	Ø 457 x 152	Polyurethane
ACR 100*	100 000	50 000	500 to 6 000	14 to 140 or 10 to 200	Ø 559 x 178	Polyurethane
ACR 200*	200 000	100 000	600 to 6 500	10 to 100 or 8 to 185	Ø 559 x 180	Steel
					Ø 559 x 356	Polyurethane
ACR 300*	300 000	150 000	1 000 to 7 500	10 to 100 or 8 to 185	Ø 559 x 203	Steel
ACR 500*	500 000	250 000	1 000 to 7 500	10 to 100 or 8 to 185	Ø 559 x 300	Steel

* Available in version D (Drive double motorisation) or I (Idler roller)

Higher capacity roller beds on request.

ROTAMATIC options

Lorry

The lorry allows to move the roller beds with or without the piece.

The idler lorry and the motorised lorry can be mounted on the same line.

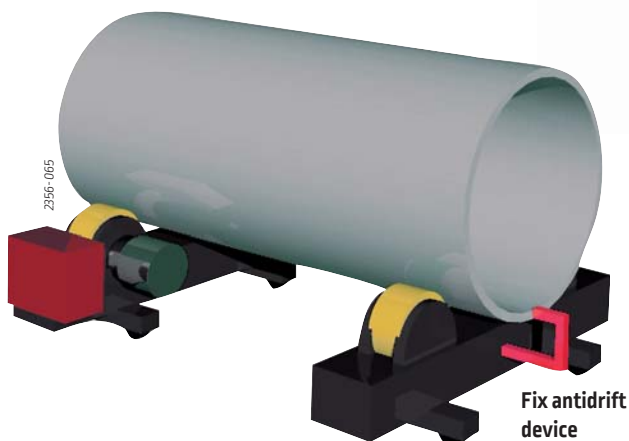
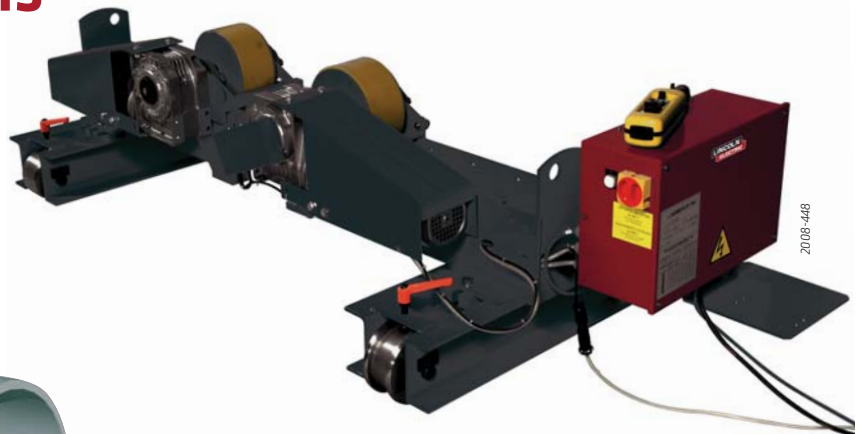

Anti-drift device

The end stop device allows the piece to turn without drifting.

An automatic solution can be proposed with a PLC which controls the idler roller positions.

POSIMATIC: positioners

2 types of positioners are available:

- Conventional: from 100 kg to 30 tons.
- With lifting table: from 1 500 kg to 10 tons.



	Load all positions kg	Tilt torque m.kg	Rotation torque m.kg	Rotation speed tr/min	Turntable height mm	Remote control or pedal	Pictures
--	-----------------------	------------------	----------------------	-----------------------	---------------------	-------------------------	----------

Conventional range

P1E	1	50	4.5	2	0.2 to 5	385	Pedal
P2E		200	40	4	0.25 to 5	500	Pedal
PS03		300	100	35	0.2 to 3	660	RC + Pedal
PS08	2	800	280	120	0.16 to 2.4	848	RC + Pedal
PS15		1 500	550	225	0.14 to 1.8	1 051	RC + Pedal
PS30	3	3 000	1 300	450	0.1 to 1.5	1 222	RC + Pedal
TP4		4 000	1 100	500	0.045 to 0.45	1 110	RC
TP6		6 000	2 500	720	0.03 to 0.3	1 150	RC
TP8		8 000	3 600	850	0.025 to 0.25	1 000	RC
TP10		10 000	6 750	1 450	0.022 to 0.22	1 190	RC
TP15	4	15 000	10 300	2 100	0.02 to 0.2	1 275	RC
TP20		20 000	14 200	2 900	0.018 to 0.18	1 340	RC
TP30		30 000	22 500	4 400	0.015 to 0.15	1 450	RC

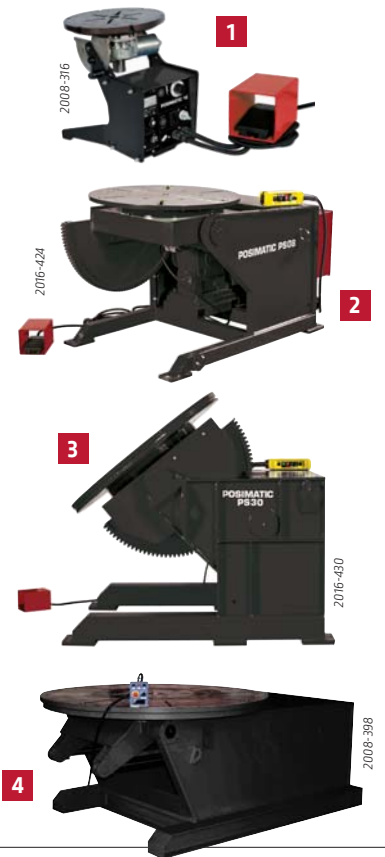

With lifting table range

TPE 1.5		1 500	375	160	0.06 to 0.6	970 to 1 700	RC
TPE 2.5	5	2 500	600	200	0.06 to 0.6	1 030 to 1 850	RC
TPE 4		4 000	1 100	500	0.045 to 0.45	1 060 to 2 010	RC
TPE 6		4 000	2 500	720	0.035 to 0.35	1 125 to 2 125	RC
TPE 8		4 000	3 600	850	0.025 to 0.25	1 125 to 2 125	RC
TPE 10		10 000	6 750	1 450	0.022 to 0.22	1 150 to 2 350	RC



Higher capacity or different rotation speed range on request.

HEADMATIC: headstock

3 types of headstock are available:

- Conventional 1 axis up to 1 ton,
- With lifting 2 axis up to 32 tons,
- With 3 axis up to 20 tons.

HEADMATIC conventional 1 axis

MINITOP, TOP and SUPERTOP II can be integrated on mechanisation with or without tailstock.

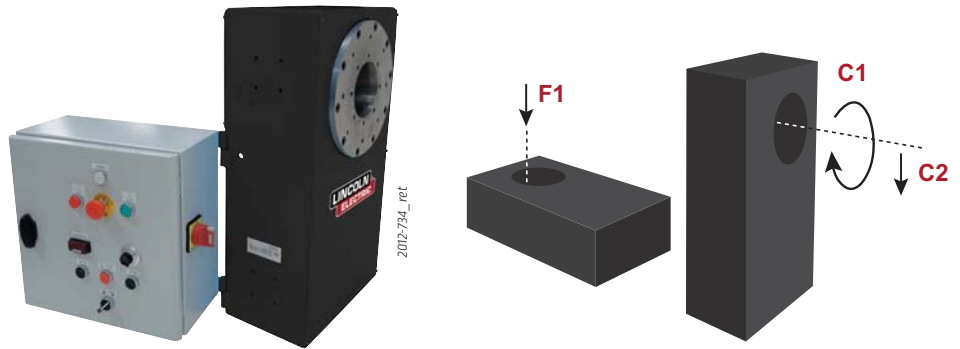

Designation	Flat Load capacity (F1) kg	Rotation torque (C1) m.kg	Tilting torque (C2) m.kg	Rotation speed tr/min
MINITOP 26.8 tr	50	3.6	14	2.7 to 26.8
MINITOP 8.25 tr	50	9.4	14	0.82 to 8.25
MINITOP 3.75 tr	50	16	14	0.37 to 3.75
TOP	300	15	90	0.05 to 4.5
SUPERTOP II	1 000	60	300	0.05 to 5

HEADMATIC 2 axis HL range

HL range with synchronized lifting movement for manual manipulation or integrated on machine. The HL machine is composed of:

- HLM: headstock,
- HLF: tailstock.

We can propose the HLM without the idler headstock and the load capacity is half of the HLM+F load capacity. Possible options: lorry and railway.

Designation	Load capacity kg	Rotation torque (C1) m.kg	Rotation speed tr/min
HLM+F 2x1.5	3 000	250	0.1 to 1
HLM+F 2x4	8 000	500	0.1 to 1
HLM+F 2x6	12 000	720	0.1 to 1
HLM+F 2x8	16 000	960	0.1 to 1
HLM+F 2x10	20 000	1200	0.1 to 1
HLM+F 2x16	32 000	1900	0.1 to 1



HEADMATIC 3 axis HL3A

Possibility to propose HEADMATIC 3 axis up to 20 tons.



TURNMATIC: turntable

Turntable 5 to 30 tons

Circular welding can be done by the movement of the turntable without moving the torch.

In the standard range, a turntable can make the rotation of shells up to 30 tons and up to 4 500 mm diameter.



2007-311



2008-362

Designation	Load capacity kg	Mini shell diameter mm	Maxi shell diameter mm	Rotation speed tr /min
TURNMATIC 5 T	5 000	1 200	4 500	0.004 to 0.204
TURNMATIC 10 T	10 000	1 000	4 500	0.004 to 0.204
TURNMATIC 20 T	20 000	1 000	4 500	0.004 to 0.204
TURNMATIC 30 T	30 000	1 000	4 500	0.004 to 0.204

Other sizes, capacities or rotation speed range on request.

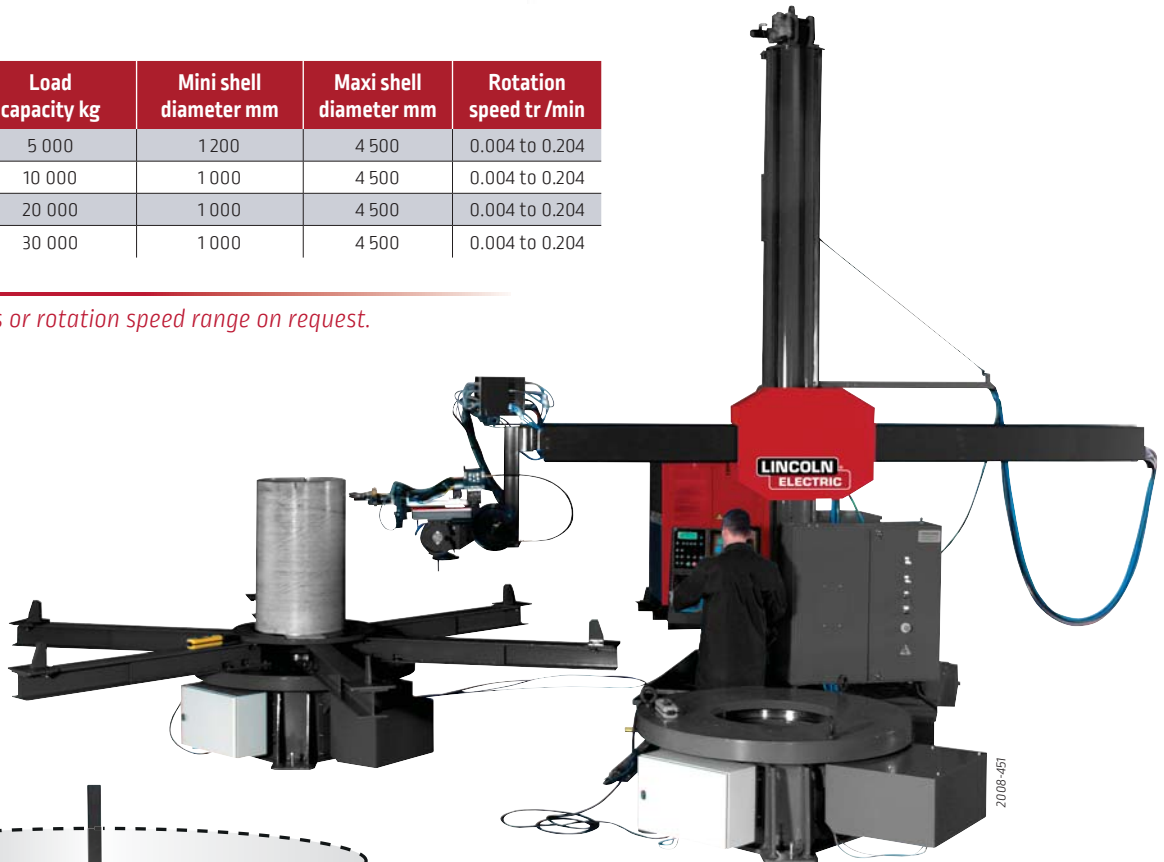

2008-457

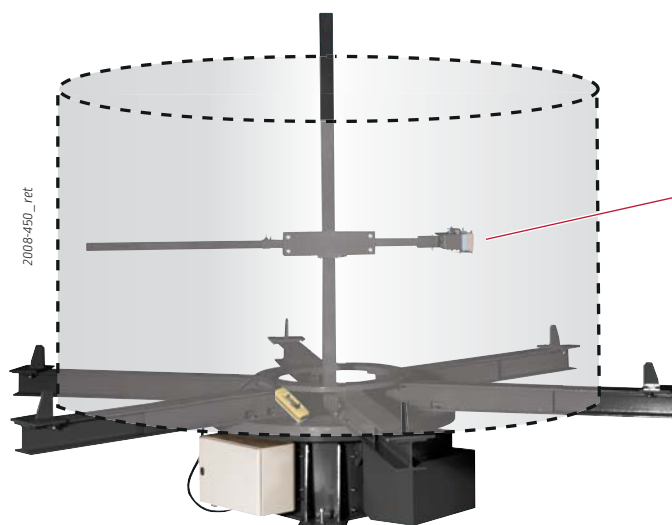

2008-460_ret

Backing gas device

The backing gas device mounted on turntable, complete the turn-key solution of plasma or TIG welding column and boom.

A man hole in the turntable allows the operator to adjust the backing gas device inside the shell.