

# WeldTec®

## WT-22, 23, 28, 29 MACHINE TORCHES DIMENSIONAL DATA SHEET

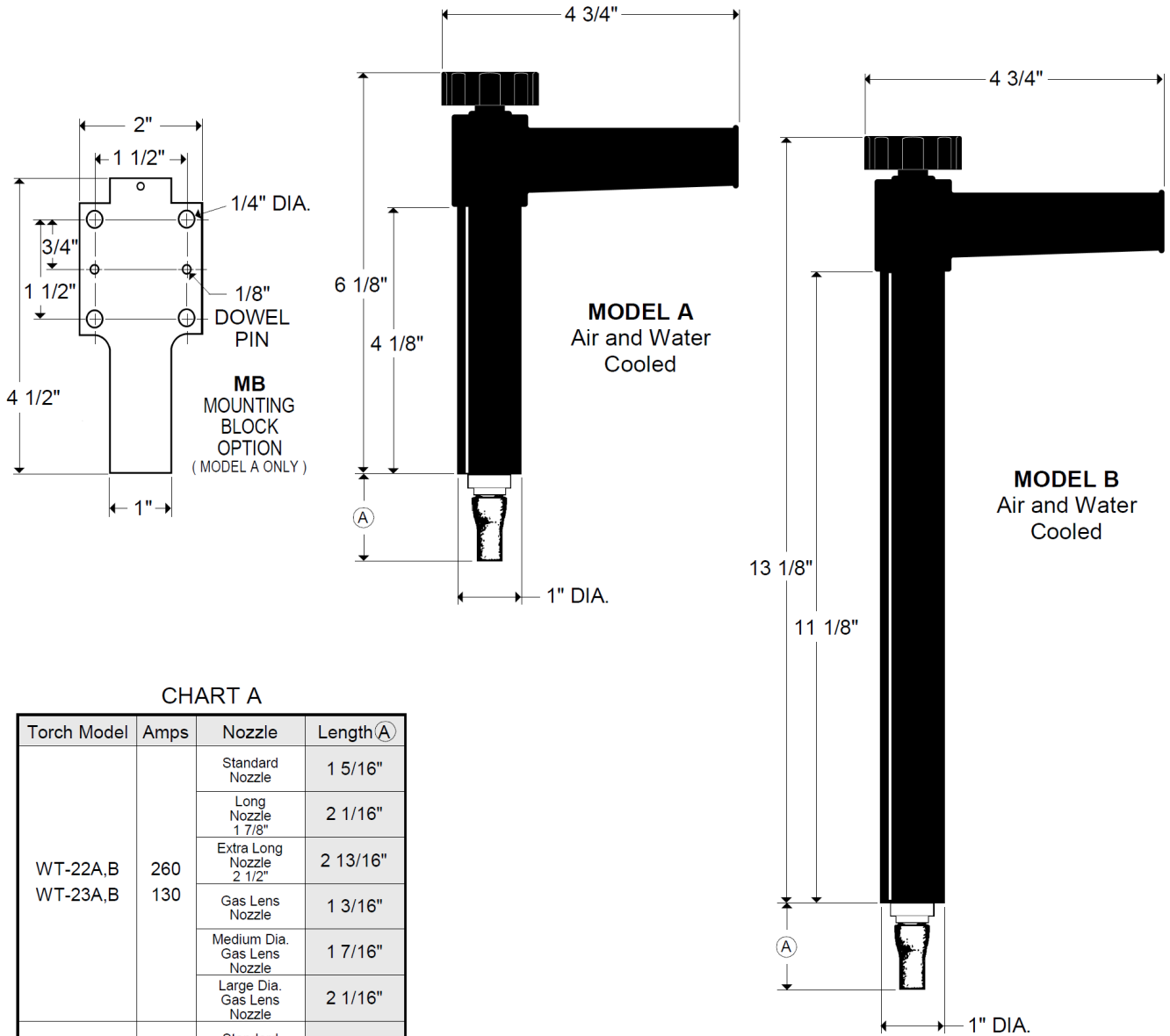

CHART A

Torch Model	Amps	Nozzle	Length (A)
WT-22A,B WT-23A,B	260	Standard Nozzle	1 5/16"
		Long Nozzle 1 7/8"	2 1/16"
		Extra Long Nozzle 2 1/2"	2 13/16"
	130	Gas Lens Nozzle	1 3/16"
		Medium Dia. Gas Lens Nozzle	1 7/16"
WT-28A,B WT-29A,B	350	Large Dia. Gas Lens Nozzle	2 1/16"
		Standard Nozzle	2 3/16"
	180	Long Nozzle 3"	3 5/16"
		Gas Lens Nozzle	2 1/4"
		Large Dia. Gas Lens Nozzle	2 3/8"

### SPECIFICATIONS

Torch Model	Maximum Amps (ac-dcsp)	Duty Cycle (ac-dcsp)	Tungsten		Cooling Requirements
			Capacity	Max. Length	
WT-22A WT-22B	260	60%	.020 - 1/8	7" 14"	Water Cooled 1 Qt./min. (50 psi MAX. OUTPUT)
WT-23A WT-23B			.020 - 3/32	7" 14"	
WT-28A WT-28B	350	60%	.020 - 5/32	7" 14"	Water Cooled 1 Qt./min. (50 psi MAX. OUTPUT)
WT-29A WT-29B			.020 - 1/8	7" 14"	

# WeldTec®

## WT-27AA, 27BA, 27CA, 27AW, 27BW, 27CW

MACHINE TORCHES

### DIMENSIONAL DATA SHEET

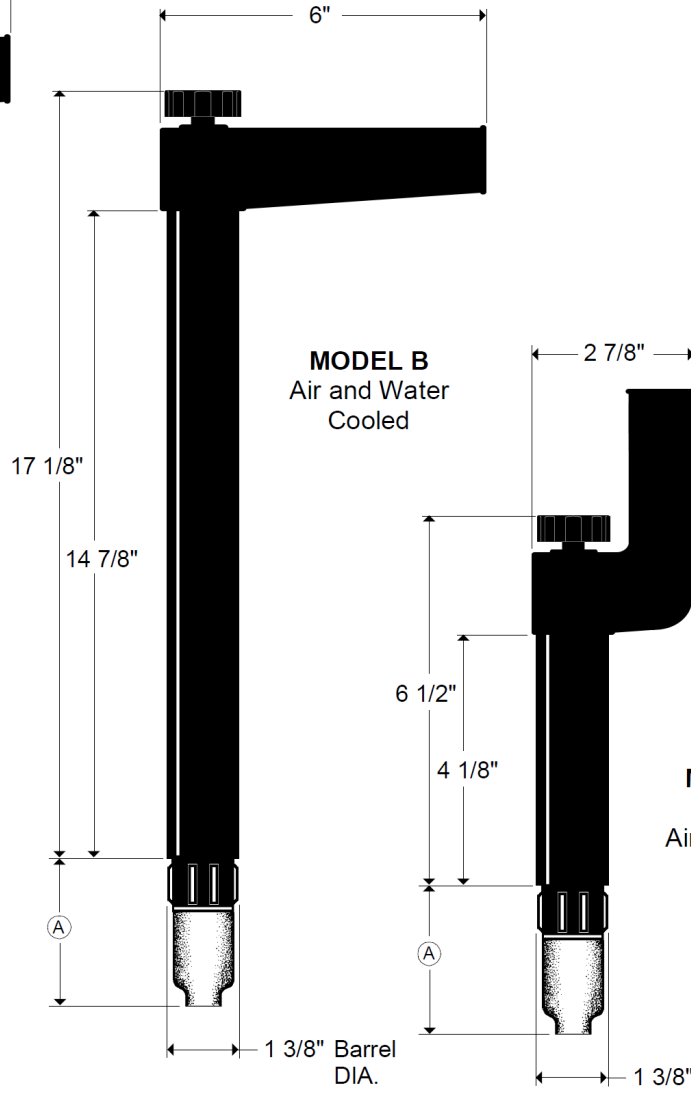
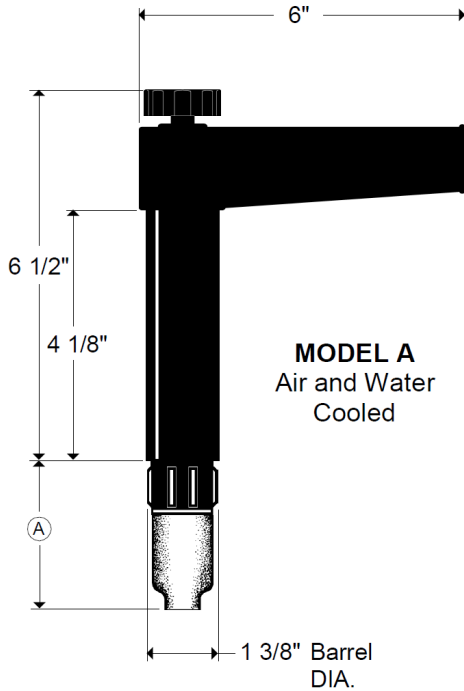

CHART A

Torch Model	Amps	Nozzle	Length (A)
WT-27AA WT-27BA WT-27CA	200	Standard Nozzle	2 3/4"
		Long Nozzle 2 3/4"	3 5/8"
		Extra Long Nozzle 3 1/4"	4 1/8"
WT-27AW WT-27BW WT-27CW	500	Extra Extra Long Nozzle 4 3/4"	5 5/8"
		Metal Nozzle	3"

### SPECIFICATIONS

Torch Model	Maximum Amps (ac-dcsp)	Duty Cycle (ac-dcsp)	*Tungsten Capacity	Max. Length	Cooling Requirements
WT-27AA WT-27BA WT-27CA	200	60%	.040 - 1/4	7" 18" 7"	Air Cooled
WT-27AW WT-27BW WT-27CW	500	60%	.040 - 1/4	7" 18" 7"	Water Cooled 2 Qt./min. (50 psi MAX. OUTPUT)

\* Axial adjustment of tungsten electrode is possible by moving the ribbed sleeve and shaft knob in unison.

# WeldTec®

## REPLACEMENT PARTS

## WT-22 WATER COOLED

Model A = 7" Model B = 14"  
MACHINE TORCHES

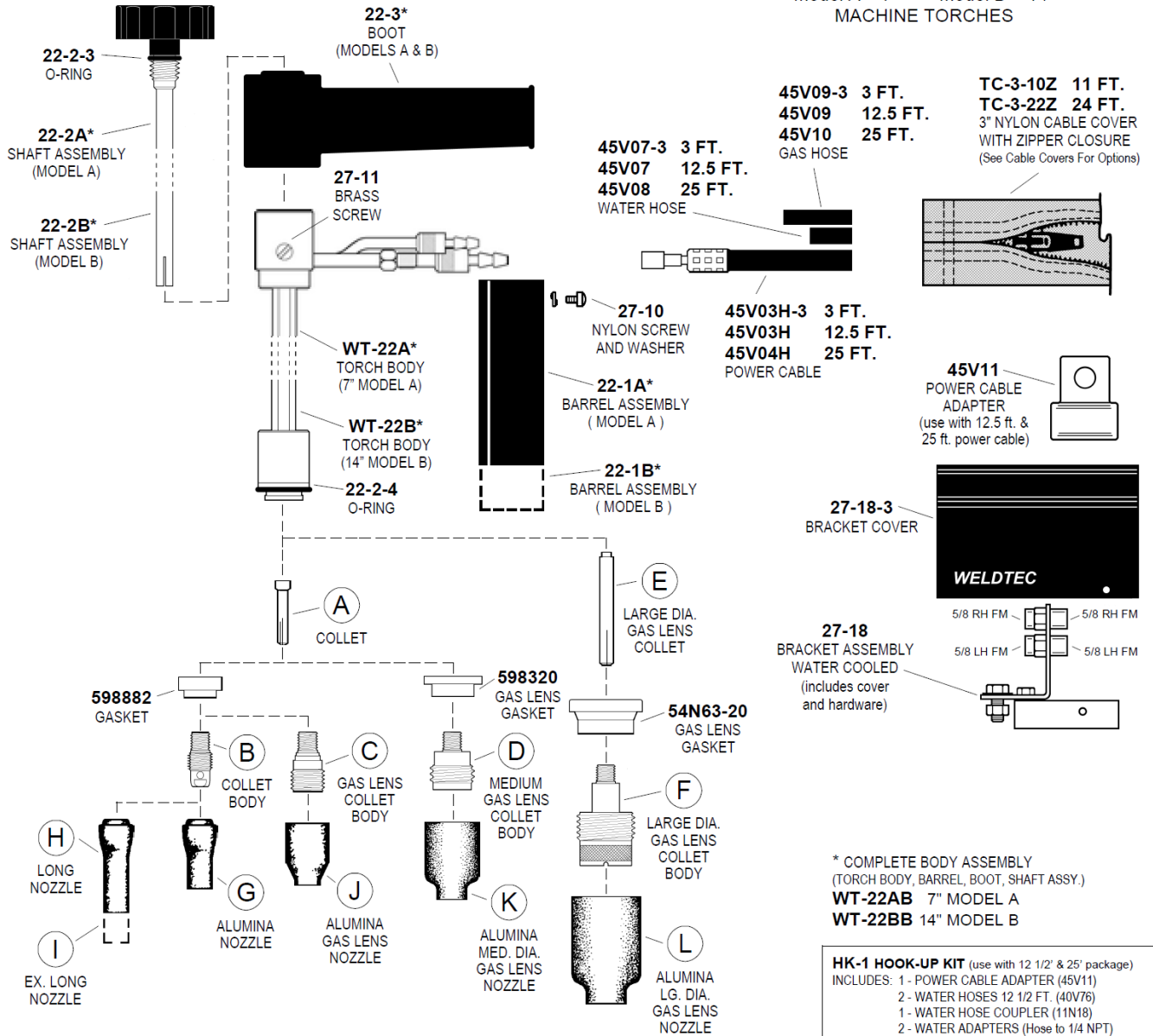

COPYRIGHT 2000 - 2016 TEC WELDING PRODUCTS, INC.

### COLLETS • COLLET BODIES • GAS LENS

ITEM	ELECTRODE DIAMETER	.020 0,5	.040 1,0	1/16 1,6	3/32 2,4	1/8 3,2
A	COLLET	13N20	13N21	13N22	13N23	13N24
B	COLLET BODY	13N25	13N26	13N27	13N28	13N29
C	GAS LENS	45V41	45V42	45V43	45V44	45V45
D	MED. DIA. GAS LENS	—	45V34SW	45V35SW	45V36SW	45V37SW
E	LG. DIA. GAS LENS COLLET	13N20L	13N21L	13N22L	13N23L	13N24L
F	LG. DIA. GAS LENS	45V0204S		45V116S	45V64S	995795S

### GAS NOZZLES

ITEM	NO. SIZE	3 3/16"	4 1/4"	5 5/16"	6 3/8"	7 7/16"	8 1/2"	10 5/8"	11 11/16"	12 3/4"
G	ALUMINA	—	13N08	13N09	13N10	13N11	13N12	13N13	—	—
H	LONG 1 7/8"	796F70A	796F71A	796F72A	796F73A	—	—	—	—	—
I	EX. LONG 2 1/2"	796F74A	796F75A	796F76A	796F77A	—	—	—	—	—
J	ALUMINA GAS LENS	—	53N58	53N59	53N60	53N61	53N61S	—	—	—
K	ALUMINA MED. DIA. GAS LENS	—	—	—	54N16SW	54N15SW	54N14SW	54N12SW	54N19	—
L	ALUMINA LG. DIA.	—	—	—	57N75	—	57N74	53N88	—	53N87*

\* #15 53N89 15/16" ID X 1 7/8" Long

# WeldTec®

## REPLACEMENT PARTS

## WT-23 AIR COOLED

Model A = 7" Model B = 14"  
MACHINE TORCHES

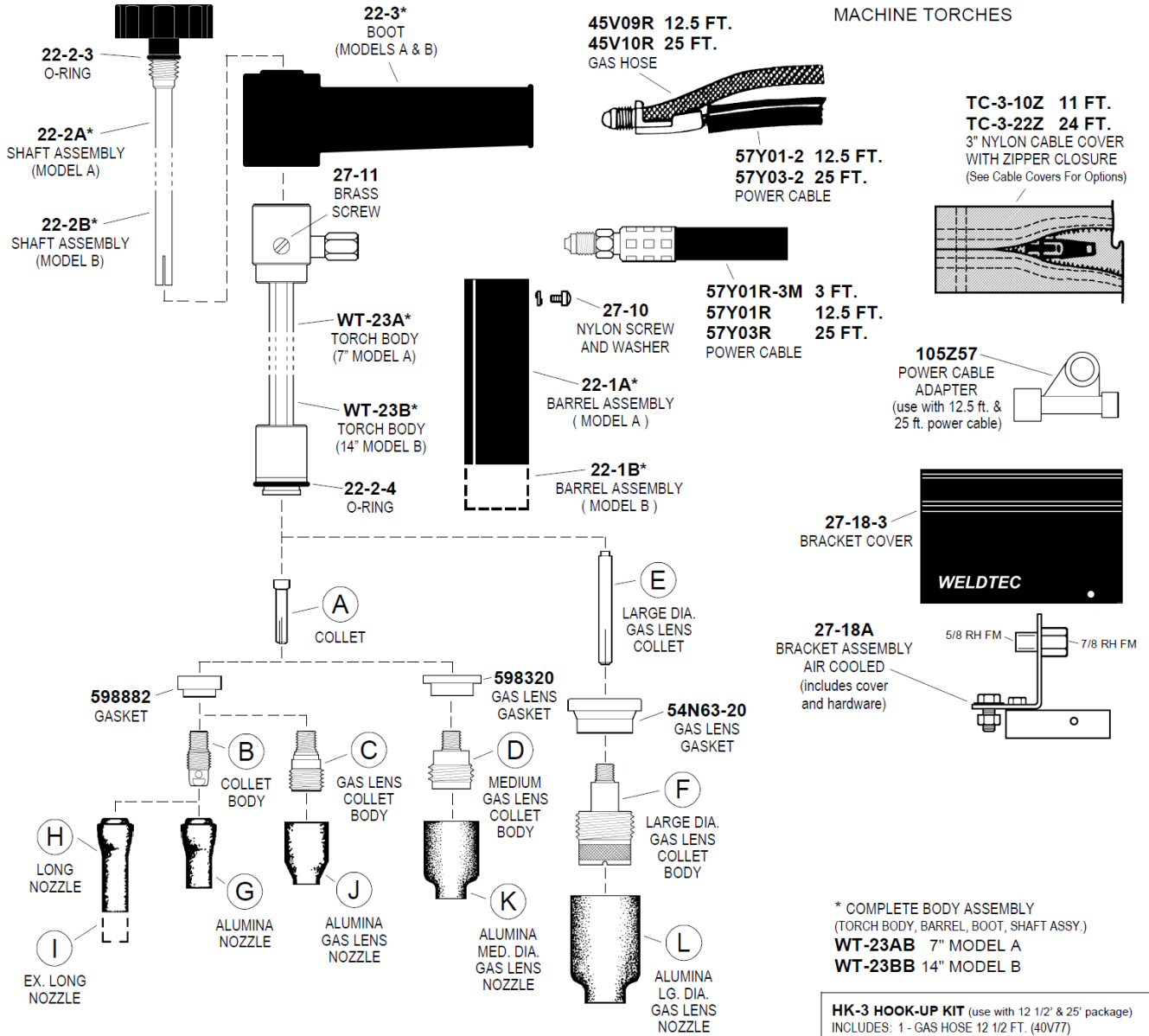

COPYRIGHT 2000 - 2016 TEC WELDING PRODUCTS, INC.

### COLLETS • COLLET BODIES • GAS LENS

ITEM	ELECTRODE DIAMETER	.020 0,5	.040 1,0	1/16 1,6	3/32 2,4
A	COLLET	13N20	13N21	13N22	13N23
B	COLLET BODY	13N25	13N26	13N27	13N28
C	GAS LENS	45V41	45V42	45V43	45V44
D	MED. DIA. GAS LENS	—	45V34SW	45V35SW	45V36SW
E	LG. DIA. GAS LENS COLLET	13N20L	13N21L	13N22L	13N23L
F	LG. DIA. GAS LENS	45V0204S		45V116S	45V64S

### GAS NOZZLES

ITEM	NO. SIZE	3 3/16"	4 1/4"	5 5/16"	6 3/8"	7 7/16"	8 1/2"	10 5/8"	11 11/16"	12 3/4"
G	ALUMINA	—	13N08	13N09	13N10	13N11	13N12	13N13	—	—
H	LONG 17/8"	796F70A	796F71A	796F72A	796F73A	—	—	—	—	—
I	EX. LONG 2 1/2"	796F74A	796F75A	796F76A	796F77A	—	—	—	—	—
J	ALUMINA GAS LENS	—	53N58	53N59	53N60	53N61	53N61S	—	—	—
K	ALUMINA MED. DIA. GAS LENS	—	—	—	54N16SW	54N15SW	54N14SW	54N12SW	54N19	—
L	ALUMINA LG. DIA. GAS LENS	—	—	—	57N75	—	57N74	53N88	—	53N87*

\* #15 53N89 15/16" ID X 1 7/8" Long

# WeldTec® REPLACEMENT PARTS WT-27AA • WT-27BA • WT-27CA

**AIR COOLED**

Model A = 9" Model B = 20" Model C = 9" Robotic MACHINE TORCHES

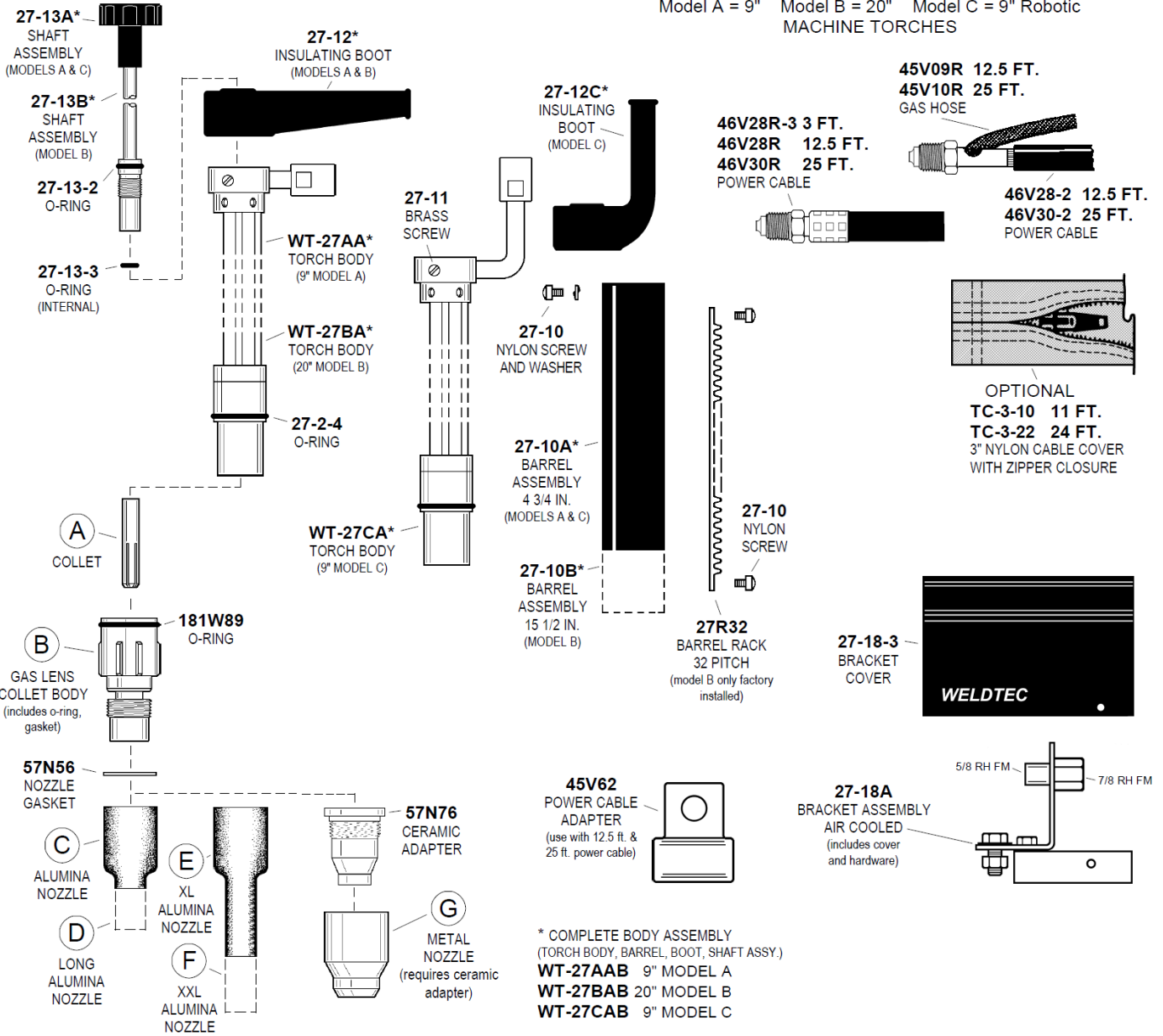

COPYRIGHT 2000 - 2015 TEC WELDING PRODUCTS INC.

## COLLETS • COLLET BODIES • GAS LENS

ITEM	ELECTRODE DIAMETER	1/16 1,6	3/32 2,4	1/8 3,2	5/32 4,0	3/16 4,8	1/4 6,4
A	COLLET	57N46	57N47	57N48	57N49	57N50	57N51
B	GAS LENS COLLET BODY	49V23	49V24	49V25	49V26	49V27	49V28

### INDIVIDUAL ACCESSORY KITS

**AK-27-18** INCLUDES: 1/8 COLLET AND GAS LENS COLLET BODY, 1 - #10 NOZZLE, 2 - #12 NOZZLES, 1/8 X 7" TUNGSTEN ELECTRODE.

## GAS NOZZLES

ITEM	NO. SIZE	LENGTH	6 3/8"	7 7/16"	8 1/2"	10 5/8"	12 3/4"	15 15/16"
C	ALUMINA LG. DIA. GAS LENS	1 7/8"	57N75	—	57N74	53N88	53N87	53N89
D	LONG ALUMINA	2 3/4"	57N75L	—	57N74L	53N88L	53N87L	—
E	XL ALUMINA	3 1/4"	57N75XL	—	57N74XL	53N88XL	53N87XL	—
F	XXL ALUMINA	4 3/4"	57N75XXL	—	57N74XXL	53N88XXL	53N87XXL	—
G	METAL	1 13/16"	—	—	—	57N78	57N77	—

\* #15 53N89 15/16" ID X 17/8" Long

# WeldTec® REPLACEMENT PARTS WT-27AW • WT-27BW • WT-27CW

## WATER COOLED

Model A = 9" Model B = 20" Model C = 9" Robotic MACHINE TORCHES

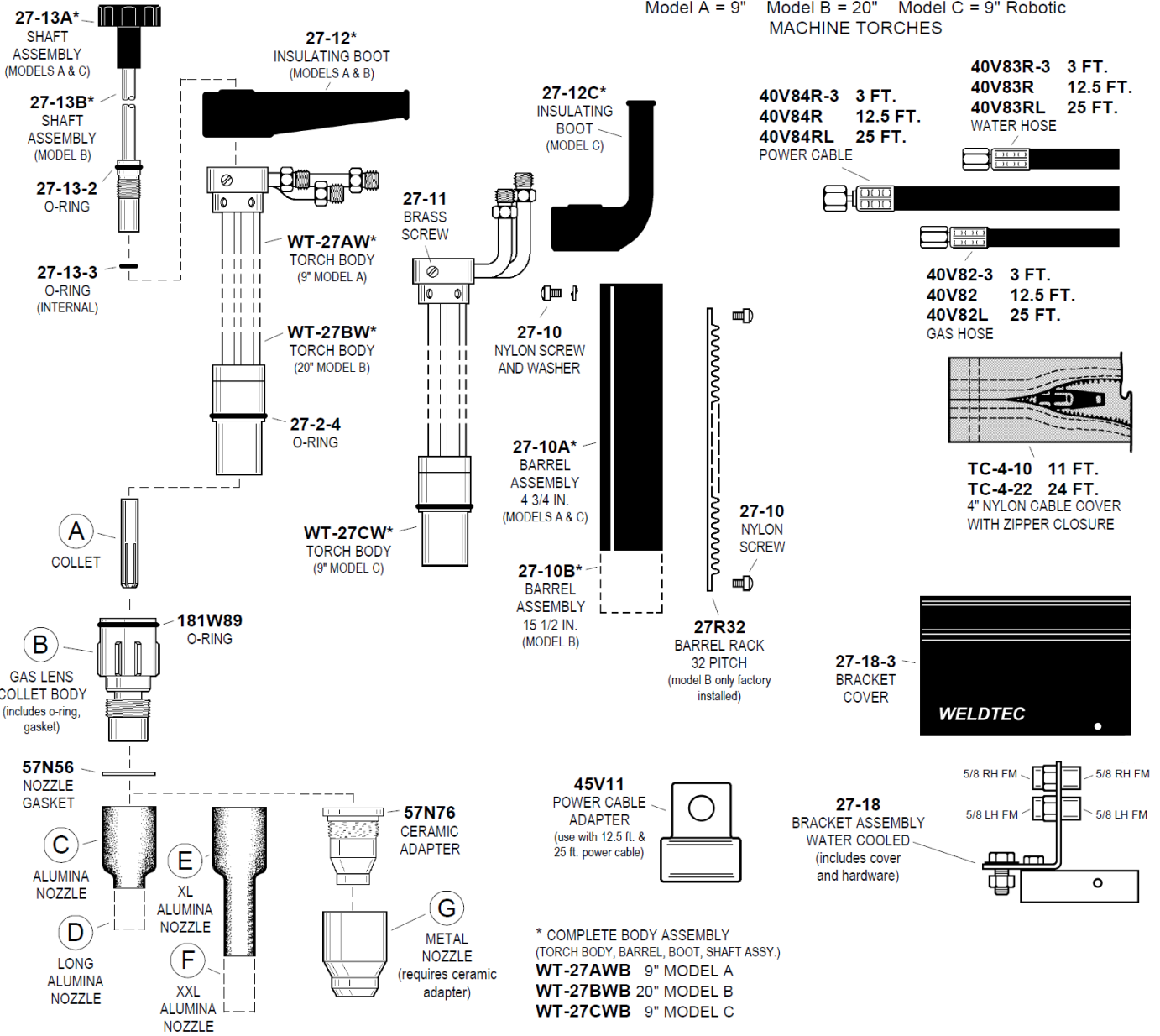

COPYRIGHT 2000 - 2015 TEC WELDING PRODUCTS INC.

### COLLETS • COLLET BODIES • GAS LENS

ITEM	ELECTRODE DIAMETER	1/16 1,6	3/32 2,4	1/8 3,2	5/32 4,0	3/16 4,8	1/4 6,4
A	COLLET	57N46	57N47	57N48	57N49	57N50	57N51
B	GAS LENS COLLET BODY	49V23	49V24	49V25	49V26	49V27	49V28

### INDIVIDUAL ACCESSORY KITS

**AK-27-18** INCLUDES: 1/8 COLLET AND GAS LENS COLLET BODY, 1 - #10 NOZZLE, 2 - #12 NOZZLES, 1/8 X 7" TUNGSTEN ELECTRODE.

### GAS NOZZLES

ITEM	NO. SIZE	LENGTH	6 3/8"	7 7/16"	8 1/2"	10 5/8"	12 3/4"	15 15/16"
C	ALUMINA LG. DIA. GAS LENS	1 7/8"	57N75	—	57N74	53N88	53N87	53N89
D	LONG ALUMINA	2 3/4"	57N75L	—	57N74L	53N88L	53N87L	—
E	XL ALUMINA	3 1/4"	57N75XL	—	57N74XL	53N88XL	53N87XL	—
F	XXL ALUMINA	4 3/4"	57N75XXL	—	57N74XXL	53N88XXL	53N87XXL	—
G	METAL	1 13/16"	—	—	—	57N78	57N77	—

\* #15 53N89 15/16" ID X 17/8" Long

# WeldTec®

## REPLACEMENT PARTS

## WT-28 WATER COOLED

Model A = 7" Model B = 14"  
MACHINE TORCHES

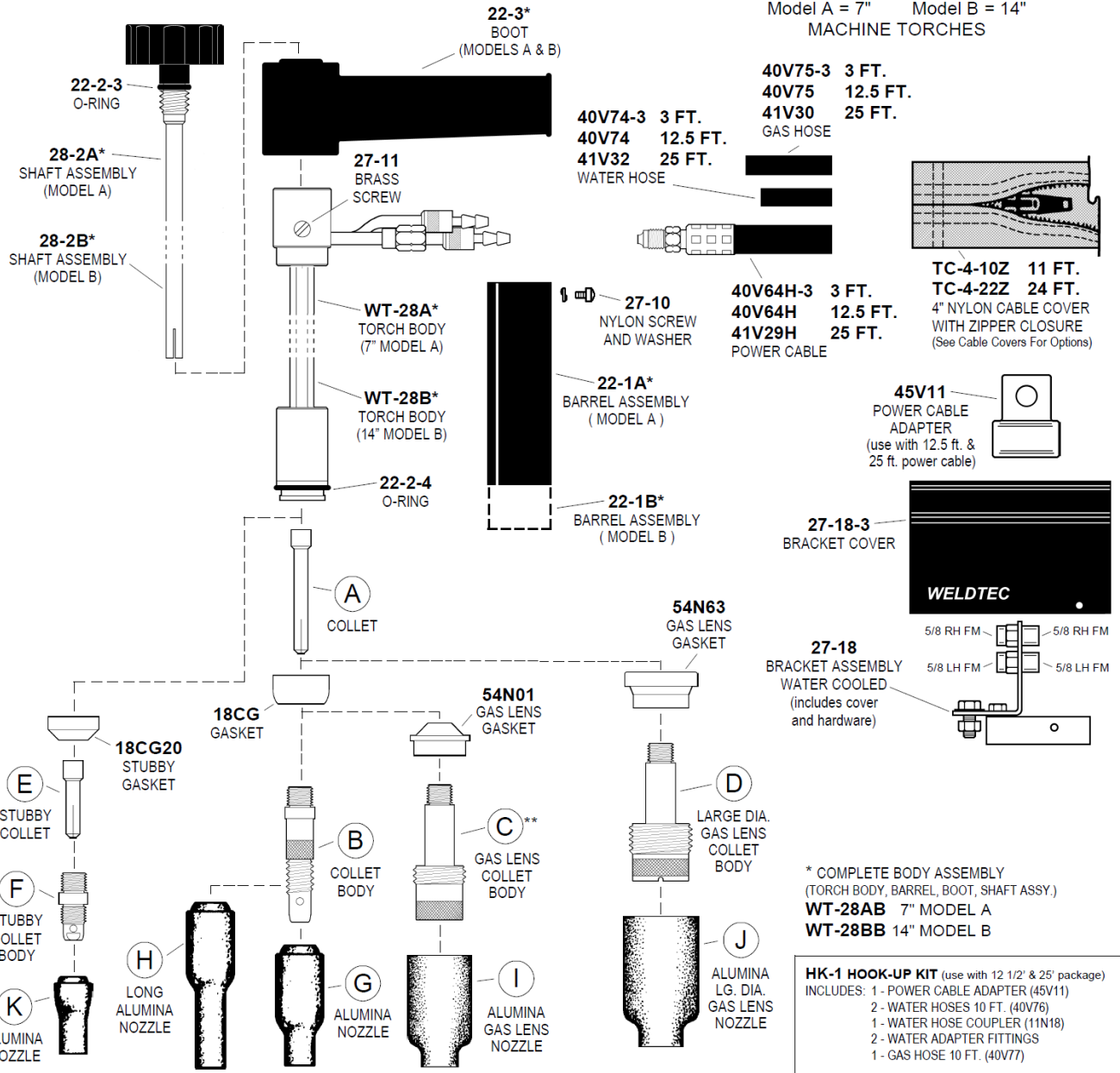

COPYRIGHT 2000 - 2016 TEC WELDING PRODUCTS, INC.

### COLLETS • COLLET BODIES • GAS LENS

ITEM	ELECTRODE DIAMETER	.020 0,5	.040 1,0	1/16 1,6	3/32 2,4	1/8 3,2	5/32 4,0	
A	COLLET	10N21	10N22	10N23	10N24	10N25	54N20	
B	COLLET BODY	10N29	10N30	10N31	10N32	10N28	406488	
C	GAS LENS	45V29	45V24	45V25	45V26	45V27	45V28	
D	LG. DIA. GAS LENS	45V0204		45V116	45V64	995795	45V63	
E	STUBBY COLLET	10N21S	10N22S	10N23S	10N24S	10N25S	—	
F	STUBBY COLLET BODY	17CB20					—	—

### GAS NOZZLES

ITEM	NO. SIZE	4 1/4"	5 5/16"	6 3/8"	7 7/16"	8 1/2"	10 5/8"	11 11/16"	12 3/4"
G	ALUMINA	10N50	10N49	10N48	10N47	10N46	10N45	—	10N44
H	ALUMINA 3" LONG	—	10N49L	10N48L	10N47L	—	—	—	—
I	ALUMINA GAS LENS	54N18	54N17	54N16	54N15	54N14	—	54N19	—
J	ALUMINA LG. DIA. GAS LENS	—	—	57N75	—	57N74	53N88	—	53N87*
K	ALUMINA	13N08	13N09	13N10	13N11	13N12	13N13	—	—

\* #15 53N89 15/16" ID X 17/8" Long

\*\* A shorter stubby gas lens collet body is available.

# WeldTec®

## REPLACEMENT PARTS

## WT-29 AIR COOLED

Model A = 7" Model B = 14"  
MACHINE TORCHES

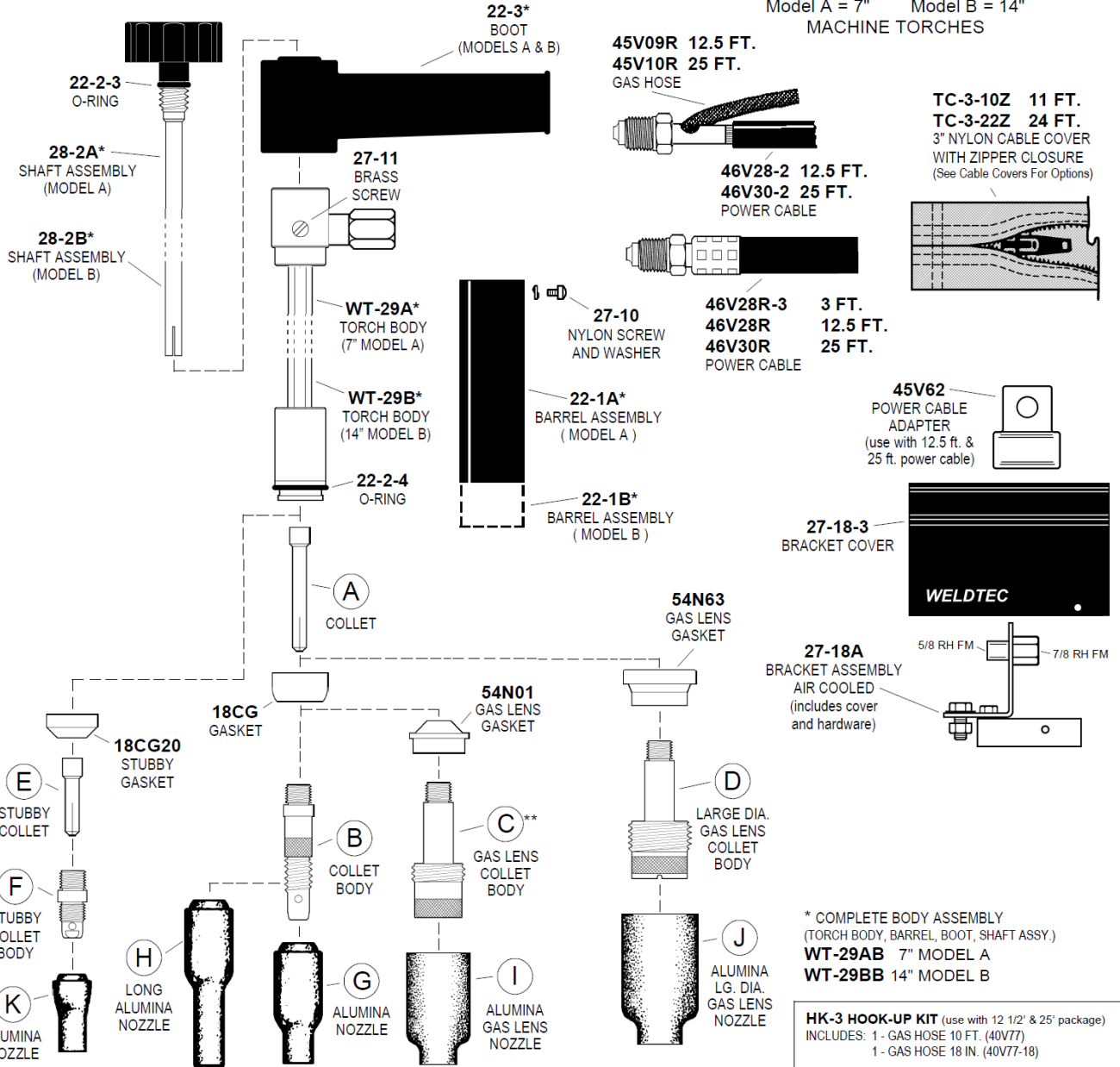

COPYRIGHT 2000 - 2016 TEC WELDING PRODUCTS, INC.

### COLLETS • COLLET BODIES • GAS LENS

ITEM	ELECTRODE DIAMETER	.020 0,5	.040 1,0	1/16 1,6	3/32 2,4	1/8 3,2
A	COLLET	10N21	10N22	10N23	10N24	10N25
B	COLLET BODY	10N29	10N30	10N31	10N32	10N28
C	GAS LENS	45V29	45V24	45V25	45V26	45V27
D	LG. DIA. GAS LENS	45V0204		45V116	45V64	995795
E	STUBBY COLLET	10N21S	10N22S	10N23S	10N24S	10N25S
F	STUBBY COLLET BODY	17CB20				

\*\* A shorter stubby gas lens collet body is available.

### GAS NOZZLES

ITEM	NO. SIZE	4 1/4"	5 5/16"	6 3/8"	7 7/16"	8 1/2"	10 5/8"	11 11/16"	12 3/4"
G	ALUMINA	10N50	10N49	10N48	10N47	10N46	10N45	—	10N44
H	ALUMINA 3" LONG	—	10N49L	10N48L	10N47L	—	—	—	—
I	ALUMINA GAS LENS	54N18	54N17	54N16	54N15	54N14	—	54N19	—
J	ALUMINA LG. DIA. GAS LENS	—	—	57N75	—	57N74	53N88	—	53N87*
K	ALUMINA	13N08	13N09	13N10	13N11	13N12	13N13	—	—

\* #15 53N89 15/16" ID X 1 7/8" Long