

P series

Sheet fiber laser cutting machine
High performance model



A - 7400 Oberwart, Kreuzgasse 1
Tel: +43 (0) 3352 210 88 - 0
Fax: +43 (0) 3352 210 88 - 3
E-mail: office@weld-tec.com

www.weld-tec.com



**Ultimate high speed and
intelligent operation**



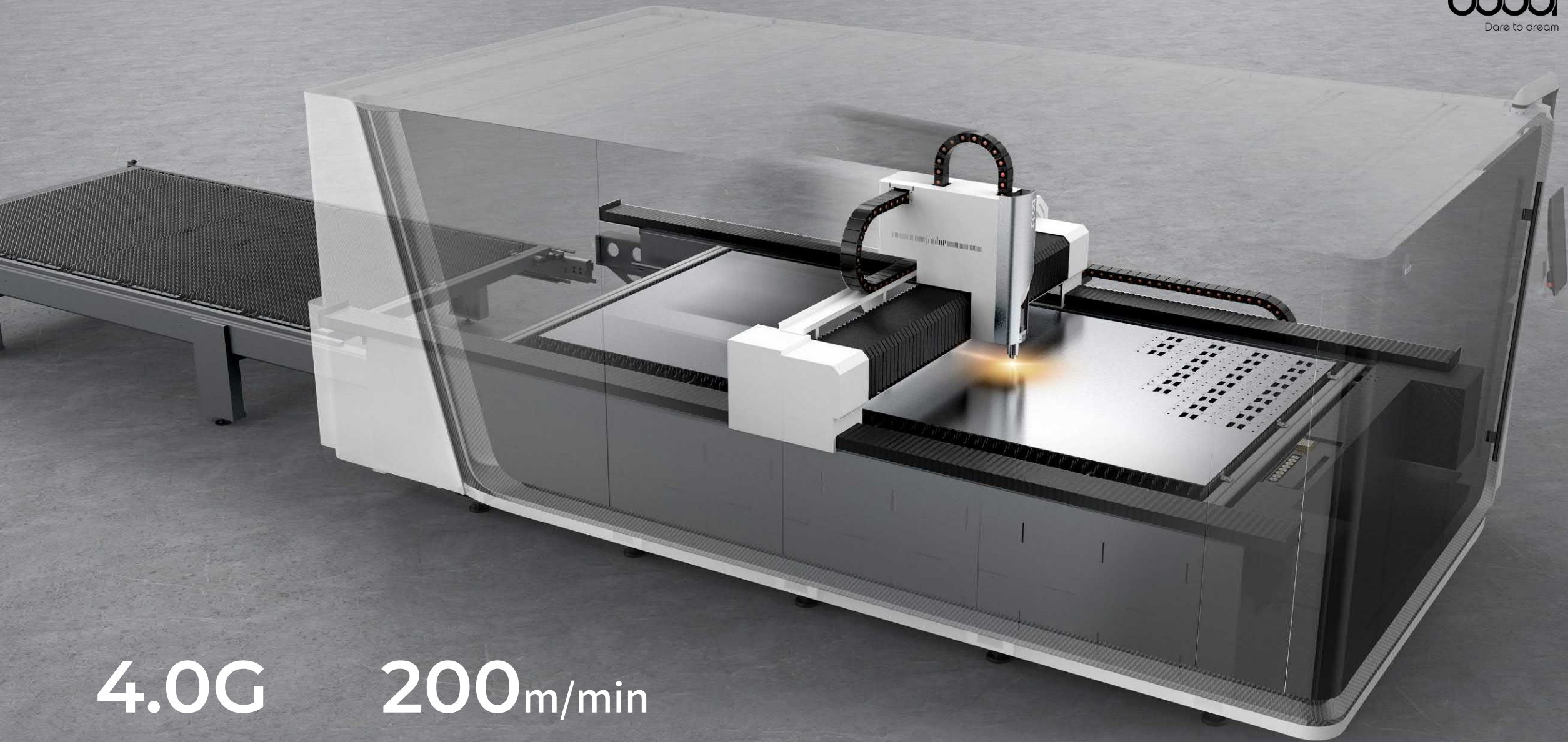

4.0G

Maximum acceleration

200m/min

Maximum drive speed

The latest 2nd generation mortise and tenon welded bed

Newly upgraded second-generation mortise and tenon welded bed, the optimal stress point and support structure are achieved by finite element analysis. The deformation during loading is significantly reduced, compared with the first-generation mortise and tenon welded bed, ensuring long-term stable machine operation.

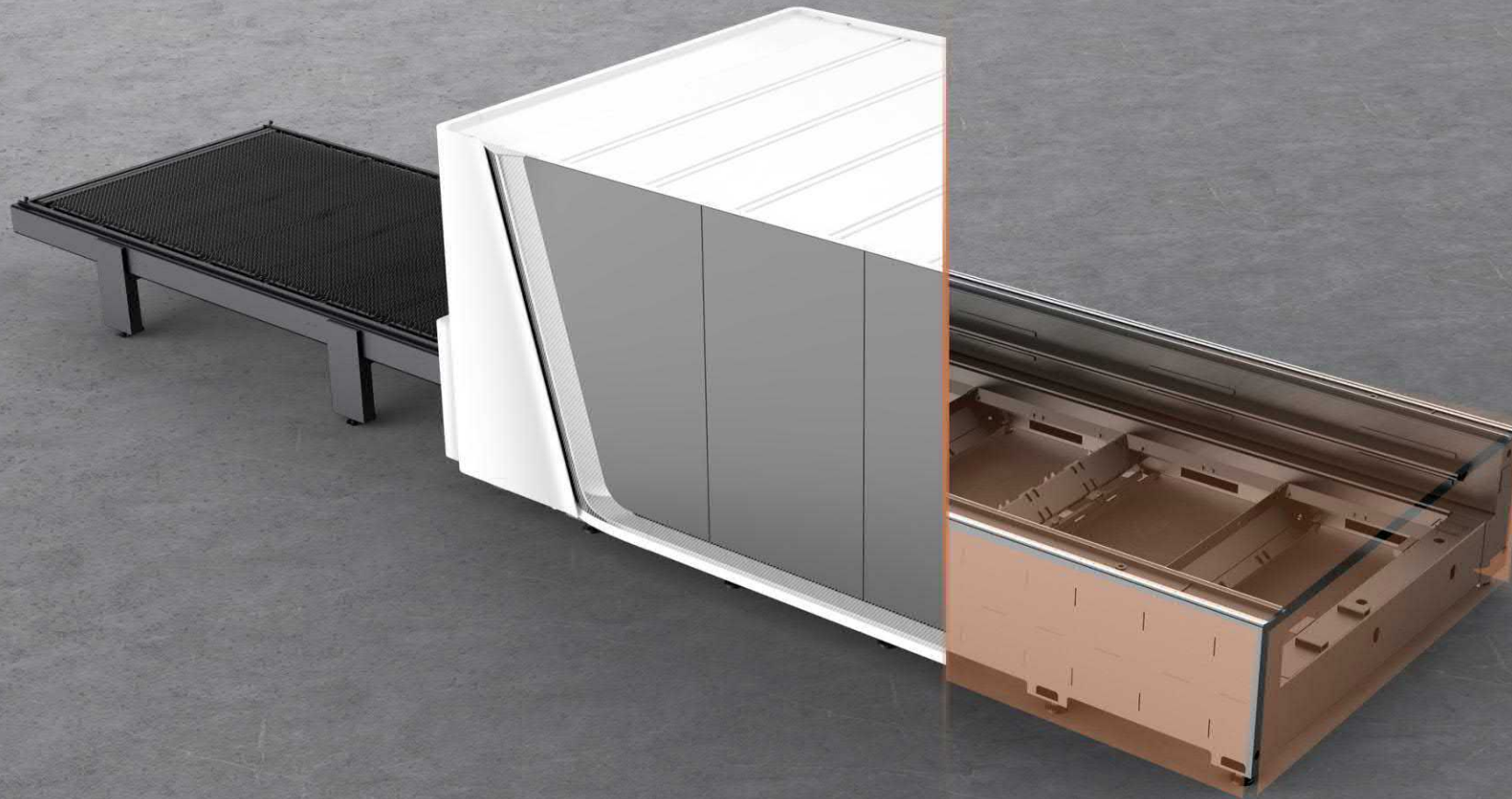

Available for all P-Series models

Equipment immediately stops running when camera detects the presence of people on the table;

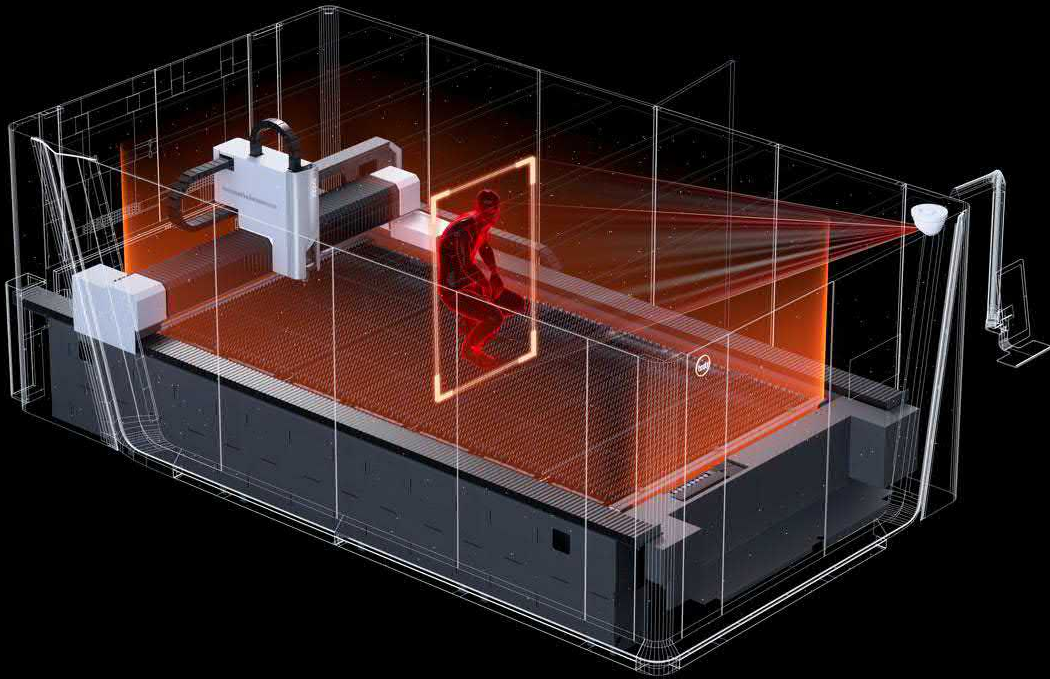

Equipment immediately stops running when the camera detects people entering through the side door.

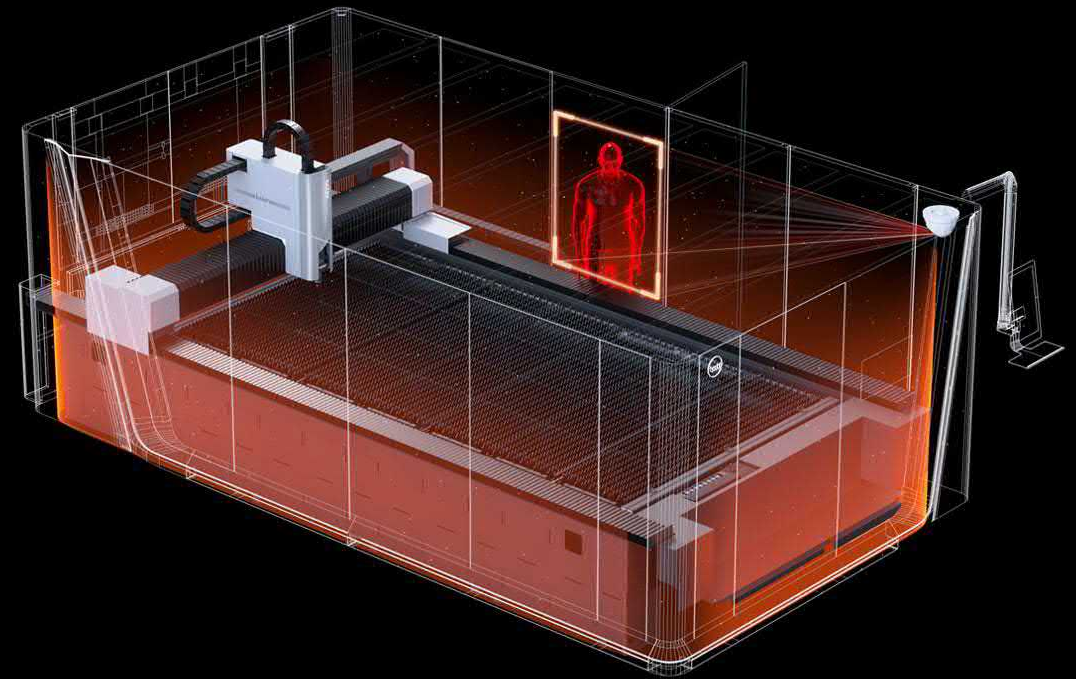

Visual anti-collision function ensures safe operation of the equipment and worry-free production.

One click processing

One click to set up and start the processing task, to complete automatic exchange, automatic edge seeking and automatic cutting, effectively reducing repeated manual labor during batch cutting and improving the machine processing efficiency.

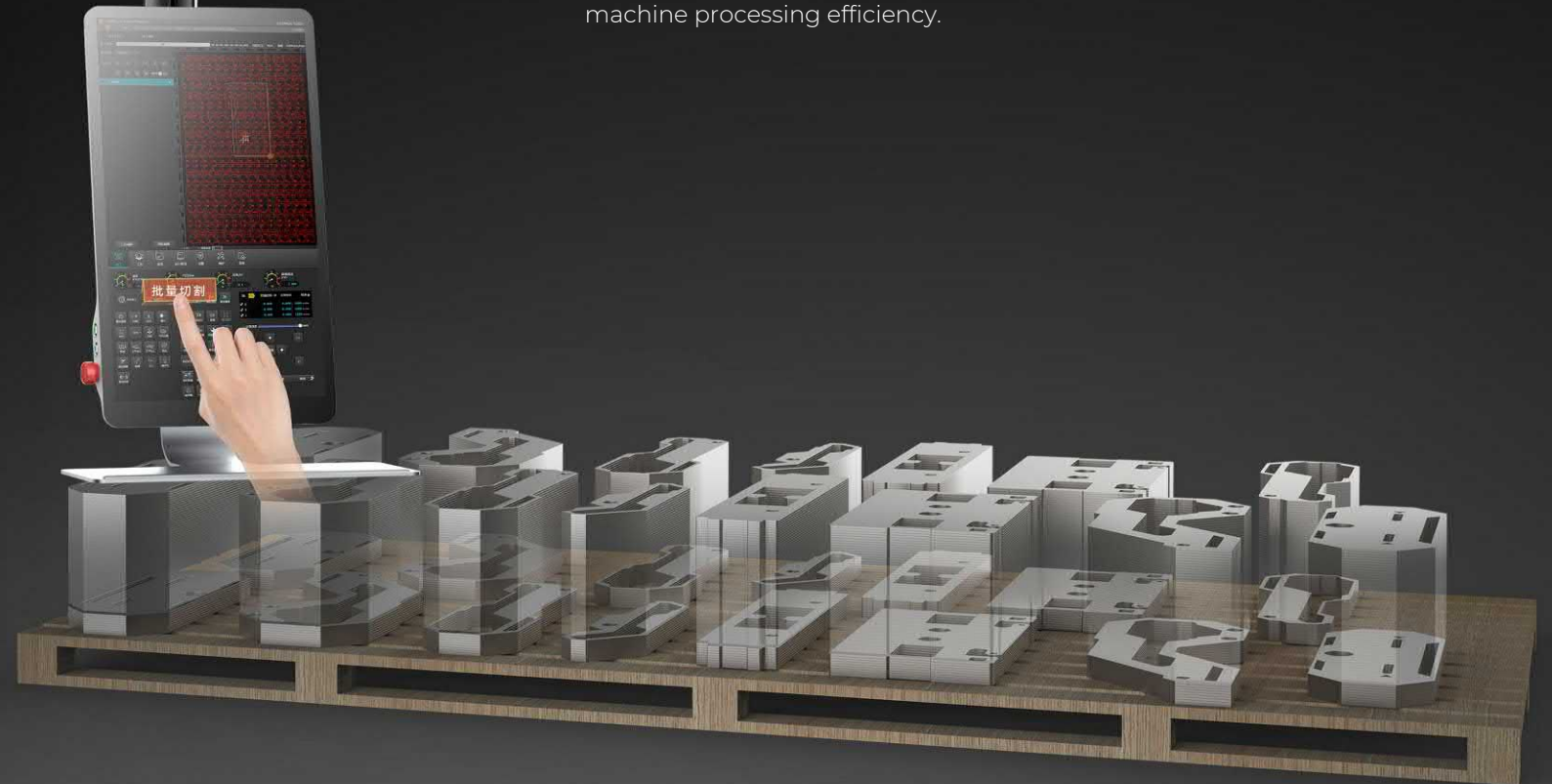



Thick plate over-heat compensation

Automatically calculates and compensates for the "drift" of the cutting head focus from multiple dimensions, such as time and temperature.

Ensures long and stable cutting of medium and thick plates without the need for manual intervention

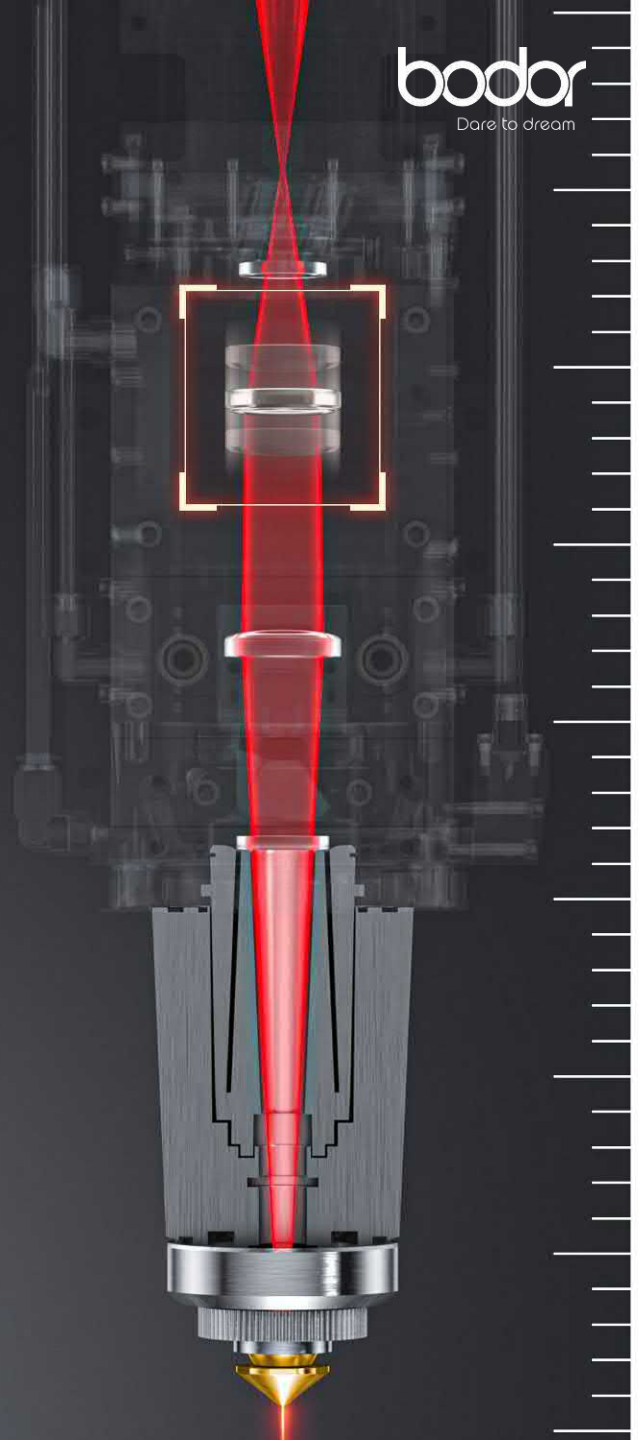

Intelligent gas pressure controlling

Real-time detection and adjustment of gas pressure through closed-loop control, ensuring consistent cutting to achieving completely stable batch processing results.

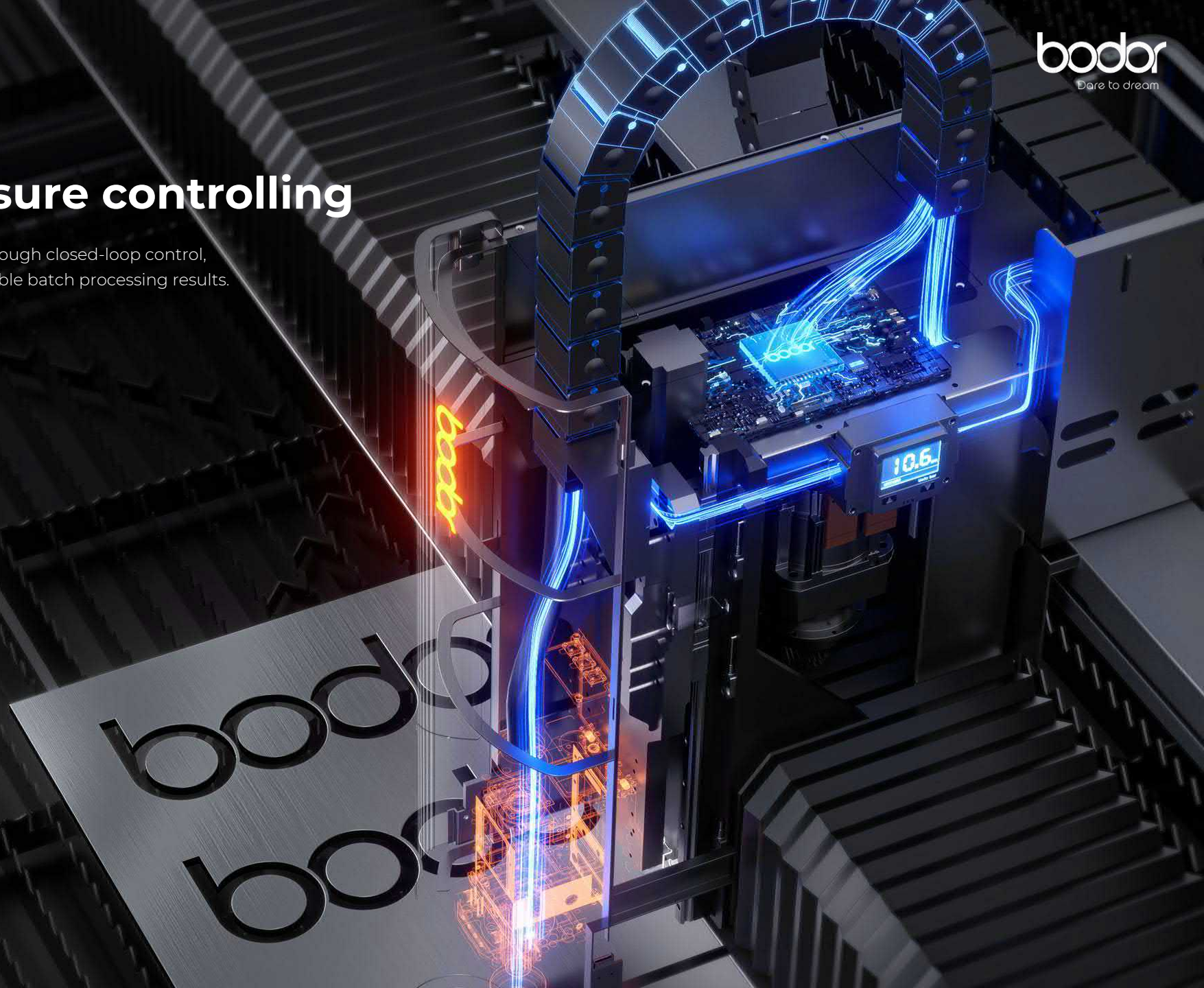

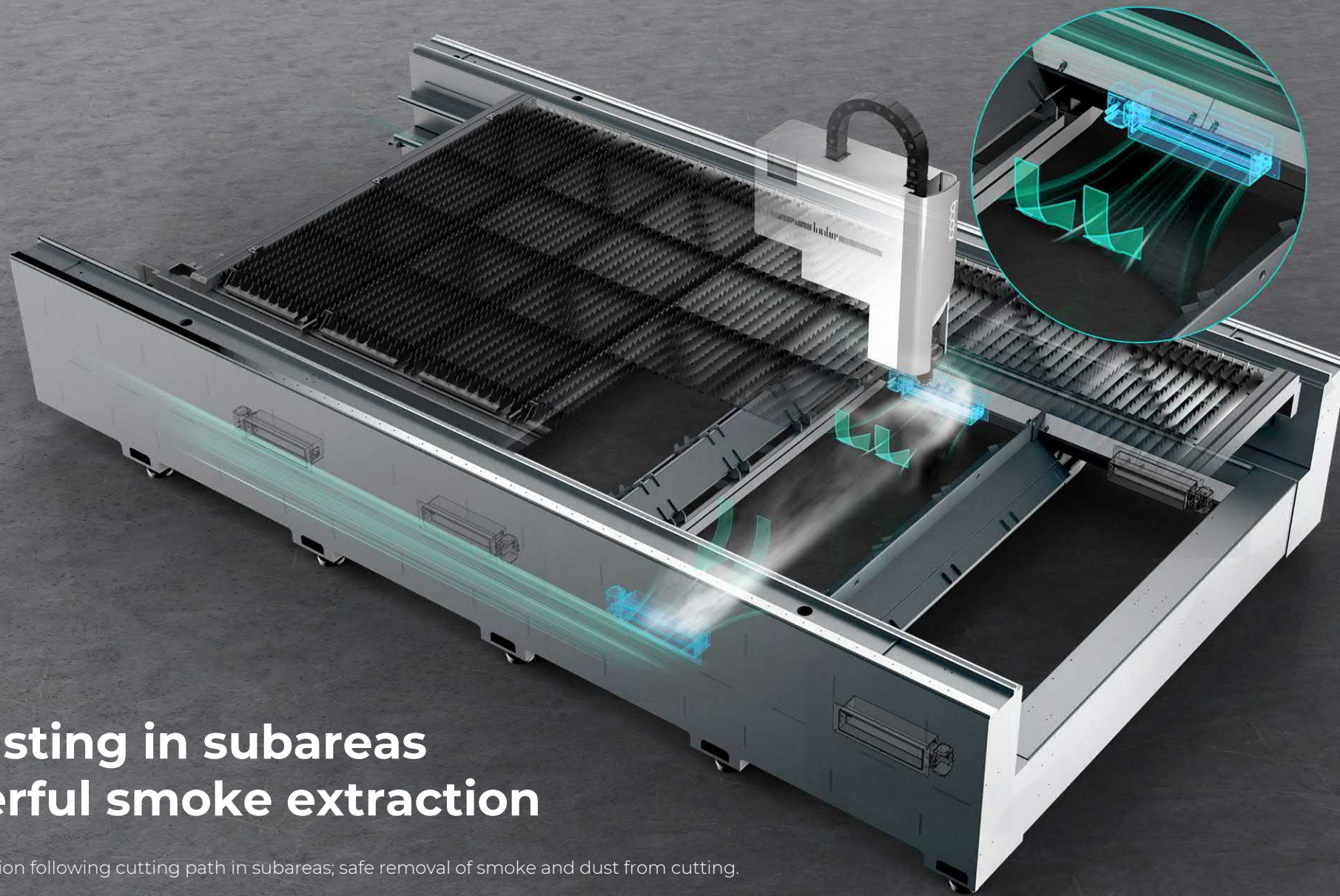

Dedusting in subareas powerful smoke extraction

Smoke extraction following cutting path in subareas; safe removal of smoke and dust from cutting.

Laser head **active obstacle avoidance**

Self-developed servo-following sensing and paths avoidance algorithm, significantly reduce the risk of laser head collision caused by workpiece warping



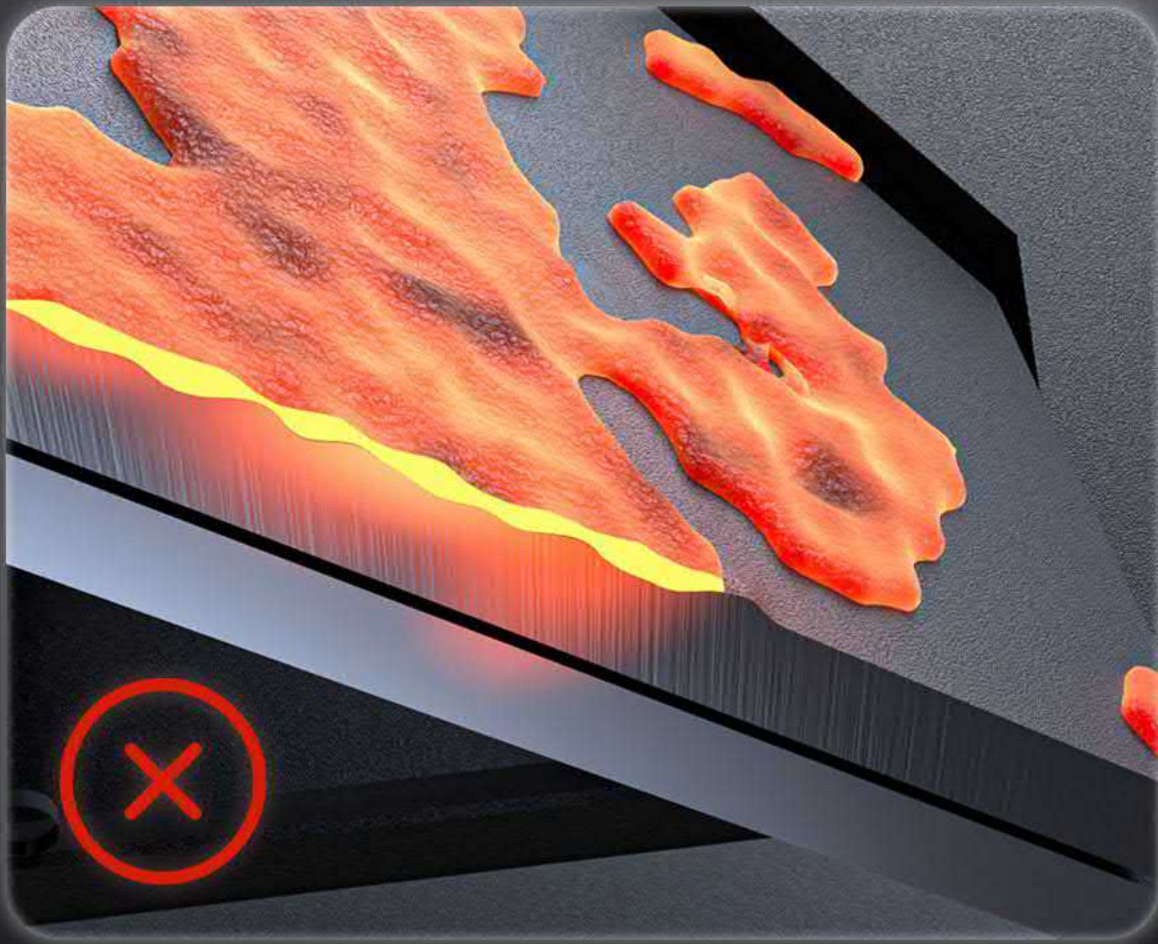

Mineral casting anti-burning plate

Easy slag clean-up, long service life: compared with anti-burning cast iron and anti-burning steel plate, it is less prone to deformation, flexible in size, and can perfectly protect the whole body of the machine.



Technical processing sharing

Accessories online store

Auxiliary operation

Equipment real time monitoring

Regular maintenance reminder

One click malfunction report

Bodor+

A new interactive platform for the industrial laser technology and the IoT (Internet of Things)

Integrating functions such as sharing, auxiliary operation, real-time monitoring of equipment, regular maintenance reminder, parts online purchase, and one-click failure reporting create a new ecology of full-service laser processing technology

Aircraft-grade aluminum crossbeam

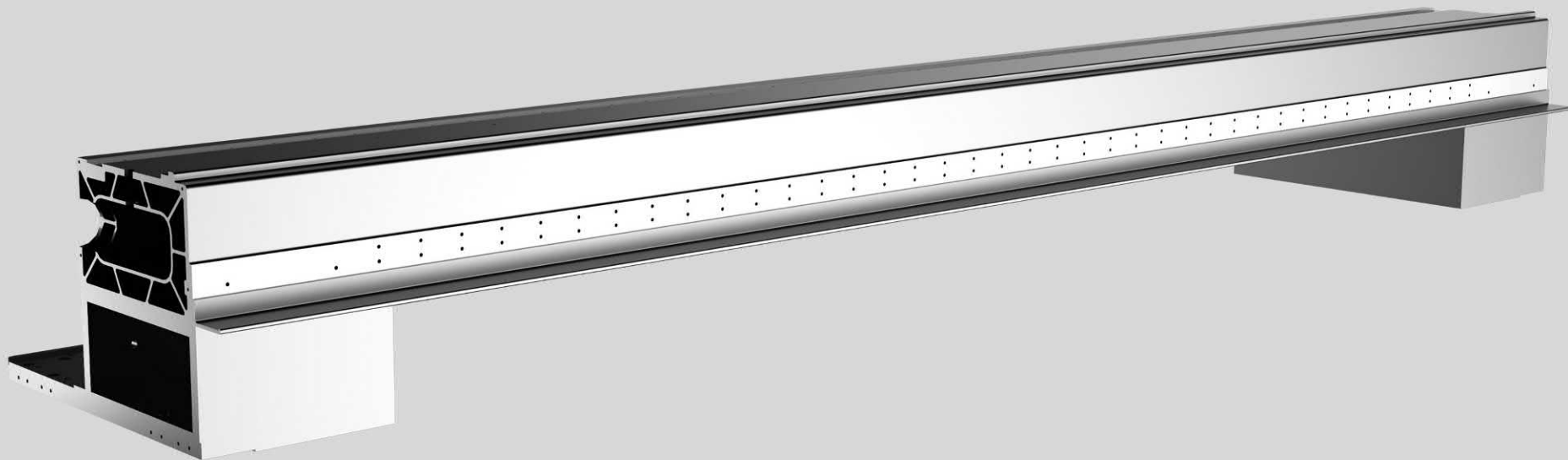

25%

Structural strength enhanced by

30%

Weight reduced by

(compared with the last generation)



Modular table

Pioneering innovation of module structured table, reducing maintenance costs.

Bodor

Six-in-one laser technology full ecology

Fully self-developed BodorThinker control system, BodorNest nesting software, BodorGenius laser head and BodorPower laser source matched with MES system and BodorDrive drive system, enabling stable operation of the machine, with premium quality cuts and incredible working efficiency.



BodorThinker
Central control system

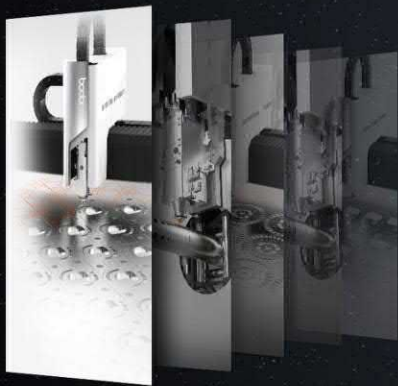

BodorNest
Nesting software



BodorGenius
Laser head



BodorPower
Laser source



BodorMES
Intelligent production
management software



BodorDrive
Drive system

Self-developed BodorPower laser

marks we have achieved the complete autonomy of developing the core components of laser equipments.



Being the core component of a laser equipment, the laser is like the engine of a car, or the CPU of a cell phone.

Over the years, laser manufacturing has been monopolized by overseas and a few domestic top-tier device manufacturers. With domestic laser enterprises only outsourcing lasers, core components quality is highly restricted and cannot be guaranteed. Bodor dares to be the pioneer to tackle the challenges of developing our own lasers, and significantly improves the efficiency of devices, bringing better processing experience for customers. own lasers, and significantly improves the efficiency of devices, bringing better processing experience for customers.

Bodor has put self-developed BodorGenius laser head in mass production.

The power ranging from 1500W to 50000W



At the final stage of laser output, laser head is critical and a determining factor to the processing quality and the efficiency of laser equipment. Bodor's self-developed laser head is equipped with multiple intelligent functions, and allow us the great confidence in "bringing our products with premium using experiences to the customers across the globe."

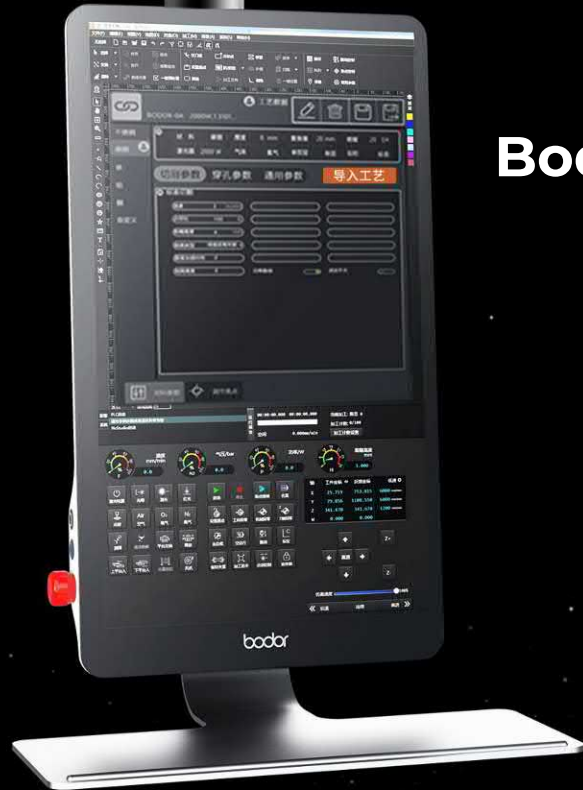

Bodor self-developed BodorThinker operating system

brings intelligent human-machine interactive experiences to our users.

Typically, complete machine manufacturers tend to install outsourced operating systems on their machine tools, which is akin to "installing someone else's head on their own body" - the poor compatibility between software and the hardware inevitably results in frequent mechanical failure

Software development is a bumpy journey. However, Bodor has been determined to develop our own operating system, starting from writing the "source code". It takes 5 years of relentless dedication for BodorThinker operating system to be successfully developed.

The autonomous operating software matched with self-developed hardware enables the smooth running of the equipments.

BodorNest, Bodor's self-developed nesting software has been successfully launched,

which achieves a perfect loop of nesting, system control and cutting optical path.

BodorNest nesting software is developed by BODOR CAMsoftware team with rich industry experience and 8 years of dedication.

BodorNest brings the efficiency of nesting operation to the next level and maximizes the utilization of plates and tubes.

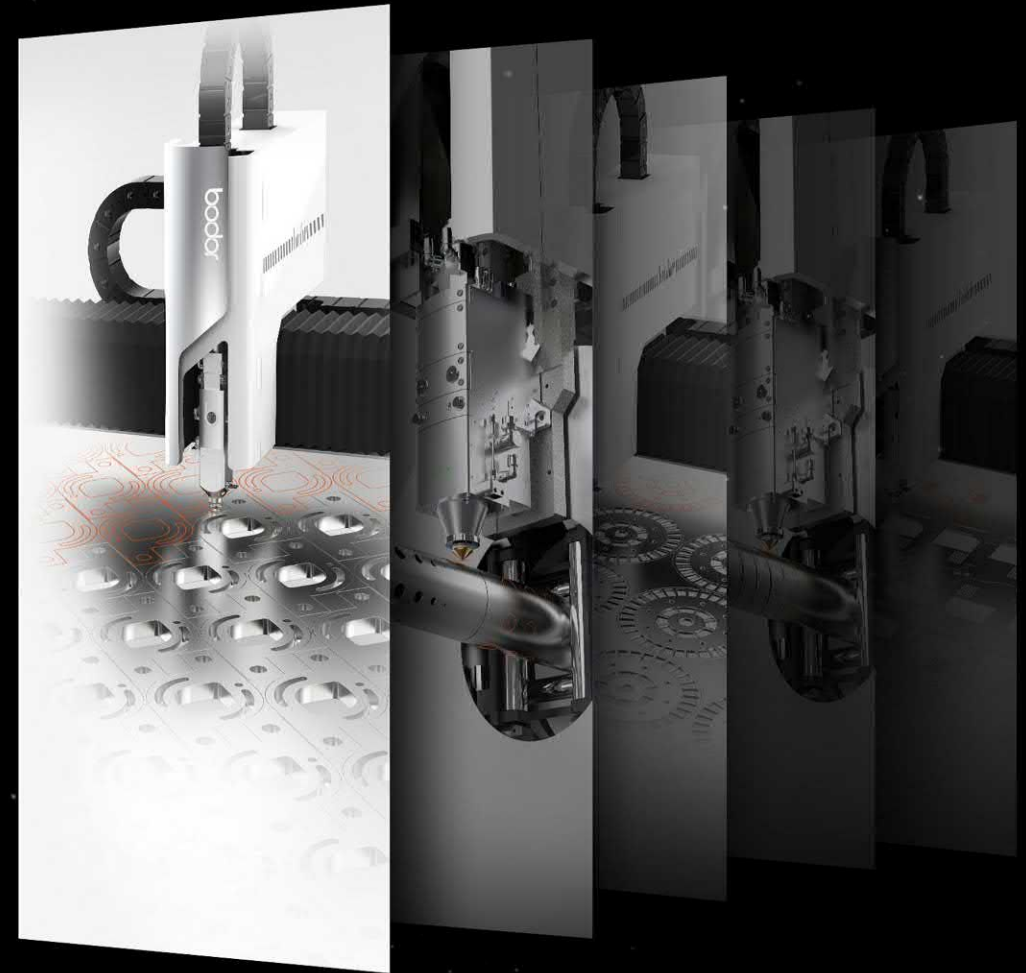

Bodor self-developed Bodor MES system, a great helper in building “smart factory”

In recent years, Chinese manufacturing has grown fast

Yet, the conventional factory management method system is relatively sloppy, with high labor cost and low efficiency, which is in urgent need of upgrades and transformation.

Bodor self-developed MES system is able to provide a “smart factory” visualization management platform, which further promotes an all-round digital transformation of factory, bringing the conventional workshop into digital era.





Bodor self-developed BodorDriver drive system

With a near-perfect inertia ratio through rigorous mechanical calculations, BodorDriver guarantees the performance and stability of the core components of driving system. Compared with outsourced standard counterparts, BodorDriver is more compatible with the high-speed reciprocating motion characteristic of laser cutting equipments.

MANGO **Wireless touch control handle**

Supports one-handed operation and comfortable grip

It can be attached to any sheet metal, and detachable at your disposal.

Reset the aesthetic standard in the era of intelligence and IOT.



(optional)

Bevel cutting of various shapes

With bevel cutting module, bevel cutting can be completed during feeding, saving processing procedures and reducing cost.

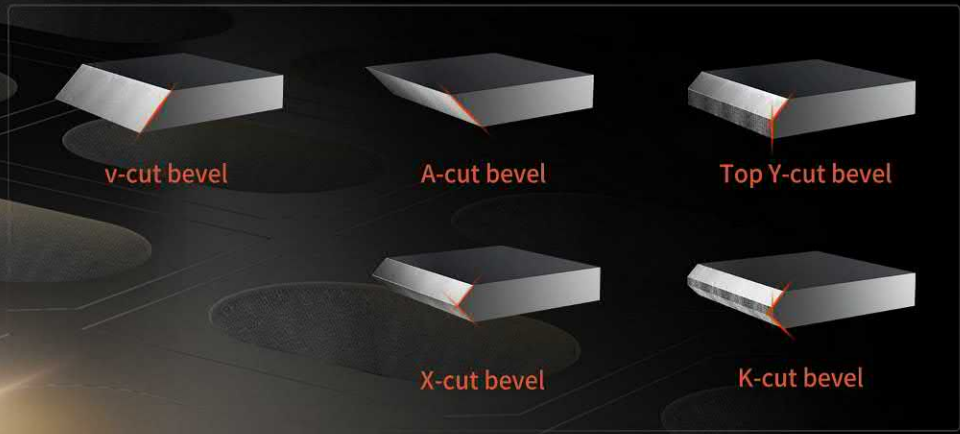

(optional)

Bodor laser scanning cutting machine pioneers a new category in the industry

dare to be the first to break the rules
transform and upgrade Chinese industry as a pathfinder.

What is scanning cutting?

Overturns the conventional processing method of laser cutting since its inception, upgrading static spot-cutting to dynamic spot cutting, with the spot traveling 30 meters for every 1 meter cut, tremendously improving the efficiency of laser energy absorption by the processed material.

3 innovative features of Scanning cutting

Faster: cutting speed up to 200% increase

Thicker: cutting thickness up to 150% increase

No fear of high reflection: During scanning cutting, the laser beam comes at tilted angle, which significantly reduces back reflection for highly reflective materials batch cutting

This is another technological breakthrough in the history of human metal cutting tools since the application of laser cutting for decades.

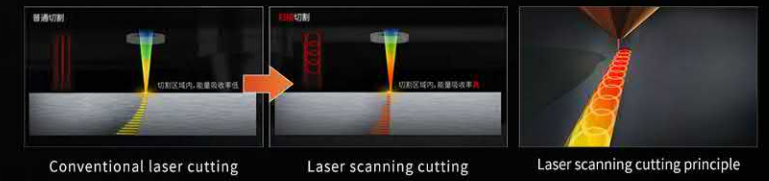

(optional)

Automated device

iTower

Single module storage tower system



(optional)

Automated device

iTrans

Automated loading and unloading system



(optional)

Automated device

iTransTower
Storage tower system



(optional)

Automated device

iLoader

Automatic small-sized workpiece sorting



(optional)

Automated device

iLoader eco





P3

3048mm*1524mm



P4

4000mm*2000mm



P6

6500mm*2500mm



P12

12500mm*2600mm

A wide range of machinable sheets format for your selection



P series Function¶meter List

	P3	P4	P6	P12
Working area	3048mm*1524mm	4000mm*2000mm	6500mm*2500mm	12500*2600mm
Max. linkage speed	200m/min	200m/min	200m/min	200m/min
Max. acceleration	4.0 G	4.0 G	2.8 G	2.8 G
One-click processing	<input checked="" type="checkbox"/>	<input checked="" type="checkbox"/>	<input checked="" type="checkbox"/>	<input checked="" type="checkbox"/>
Remnant Typesetting	<input checked="" type="checkbox"/>	<input checked="" type="checkbox"/>	<input checked="" type="checkbox"/>	<input checked="" type="checkbox"/>
SpaceEye	<input checked="" type="checkbox"/>	<input checked="" type="checkbox"/>	<input checked="" type="checkbox"/>	<input checked="" type="checkbox"/>
Visual collision detection	<input checked="" type="checkbox"/>	<input checked="" type="checkbox"/>	<input checked="" type="checkbox"/>	<input checked="" type="checkbox"/>
Automatic nozzle changer	<input checked="" type="checkbox"/>	<input checked="" type="checkbox"/>	<input checked="" type="checkbox"/>	<input checked="" type="checkbox"/>
Air pressure intelligent control	<input checked="" type="checkbox"/>	<input checked="" type="checkbox"/>	<input checked="" type="checkbox"/>	<input checked="" type="checkbox"/>
Automatic adjustment of cutting gas pressure	<input checked="" type="checkbox"/>	<input checked="" type="checkbox"/>	<input checked="" type="checkbox"/>	<input checked="" type="checkbox"/>



Ultimate high speed and intelligent operation

bodor

Dare to dream



A - 7400 Oberwart, Kreuzgasse 1

Tel: +43 (0) 3352 210 88 - 0

Fax: +43 (0) 3352 210 88 - 3

E-mail: office@weld-tec.com

www.weld-tec.com

*welding .
cutting .
automation .
service .*